

AHARONIAN
& ASSOCIATES, INC.
Architects

May 31, 2023

TO: All Bidders

**RE: Fogarty Memorial School
BOILERS REPLACEMENT**
732 Snake Hill Road
North Scituate, RI 02857
AA# 23018

ADDENDUM #1

The Contract Documents for the above referenced Project are hereby modified per the following. All other Drawing and Project Manual items not addressed herein shall remain in full effect. The Bidder shall acknowledge the receipt of this Addendum on the Bid Form.

CLARIFICATIONS & REVISIONS TO DRAWINGS & SPECIFICATIONS

Items Revised have been clouded on Construction Documents.

1. Due to limited available power, wiring, and circuiting, and to eliminate the installation of a new electric panel with associated conduit and wiring, please include the following changes for to the Bid.

A. Delete reference to multiple electric water heaters as noted on Project Documents. In place of the noted multiple electric water heaters, provide one (1) Ruud Model E175A-27-G commercial electric water heater (or equal), UL-listed, ASME construction, NSF5- compliant; 175 gallons storage and 27 KW electric heating input, 112 gallons per hour recovery at 100°F rise, 208 volt/3-phase power, 75.0-amp FLA, pre-wired power and control box. Furnish complete with immersion thermostat(s) with probe-type low water cut-off, and ASME-rated temperature and pressure relief valve. Install water heater in existing Mechanical Room, in vicinity of existing/removed water storage tank. Connect to existing domestic cold water, domestic hot water, and domestic hot water recirculation piping as required. Existing domestic hot water recirculation piping loop pump shall remain in place.

B. Provide Leonard Model XL-82-LF-BDT-LF thermostatic mixing valve (or equal) mounted on wall in vicinity of new electric water heater, adjusted as required to provide 110°F outlet supply water temperature to building fixtures. Connect to existing domestic cold water, domestic hot water, and domestic hot water recirculation piping in strict accordance with mixing valve manufacturer's instructions and requirements.

2. The M1.1 Sheet dated March 24, 2023; Issued for Bid was the incorrect version. Please find attached sheet M 1.1 dated March 31, 2023.

3. Attached please find the latest Mechanical Specification sections for use in this Bid. Sections included are 22 07 00, 22 10 00, 22 30 00, 23 03 00, 23 05 93, 23 07 19, 23 321 13, 23 21 14, 23 21 23, 23 51 00 and 23 52 23.

Questions & Answers

1. How large is the existing domestic hot water storage tank?

Response: Unknown. Bidders are encouraged to reach out to Gary Gras at 1-401-568-5540 to schedule a visit to the site.

2. Is the tank glass lined or cement lined?

Response: Unknown.

3. Is there any asbestos insulation anywhere in the mechanical room? “pipe covering / domestic tank”

Response: Attached please find the asbestos inspection report by Vortex.

4. Is there an electrical panel located in the mechanical room with room for additional circuits?

Response: No, see response #17 for additional notes.

5. Is the housekeeping pad large for the new boilers?

Response: Existing pads to remain.

6. What is the existing pad size?

Response: The existing pads are large enough to allow for installation of new boilers.

7. What does the existing chimney look like? Is there a need to re-brick anything?

Response: Modification will be required to close an existing penetration with masonry to match existing construction and provide new penetration as indicated on sheet M1.1.

8. Do new hydronic specialties need to be provided for the existing building pumps?

Response: No. Main building circulation pumps are existing to remain.

9. What is the existing BMS?

Response: Schneider Electric/ In-Control.

10. Who is the existing BMS contractor?

Response: In-Control, Warwick, RI 1-401-734-9333.

11. Is there a separate plumbing drawing or scope for the new DHW design? It is vaguely shown on the M-drawings?

Response: Updates provided to this scope in this Addendum.

12. Would this work need to be carried under the boiler project?

Response: Yes.

13. Is there room above the bathroom ceiling to install (3) new electric water heaters?

Response: Yes. However, the DHW scope has been revised in this Addendum.

14. Where will power be supplied from for the new water heaters?

Response: Electric panels are located within the utility closet between the multiuser restrooms in the Central Core of the building. GC shall be responsible for design-build services as required to install all new electrical components.

15. Where is the domestic hot and cold connections point in comparison to the new EWH locations?

Response: This scope of work has been revised in this Addendum.

16. What are the kitchen conditions to install the new EWH?

Response: This scope of work has been revised in this Addendum.

17. Where will power be supplied from for the new kitchen water heaters?

Response: Electric panels are located within the utility closet between the multi user restrooms in the Central Core of the building.

18. We were not able to attend the Pre-Bid Conference on 5/24...can another site visit be coordinated?

Response: Yes. Please reach out to Gary Gras at 1-401-568-5540 to schedule a visit.

19. Can the bid date be extended to 6/16?

Response: No. The bid due date will remain as noted in the Invitation to Bid.

20. What is the budget or engineer's estimate for this project?

Response: Unknown.

21. Can the MBE/WBE requirement be waived? We are able to self-perform the entire project and, as such, do not have any trades available for subcontracting to MBE/WBE.

Response: This is a RIDE requirement. The GC will need to submit a waiver to the state for review. Our office is not permitted to waive this requirement.

ATTACHMENTS

- A. Pre-Bid Sign In Sheet.
- B. Asbestos Inspection Report by Vortex.
- C. Section 00 41 02- Bid Form.
- D. Section 01 23 00- Alternates.
- E. Mechanical Specifications Sections 22 07 00 through 23 52 23.
- F. Sheet M1.1 dated 3-31-23.

Vortex Inc.

Environmental Management, Consulting & Training Services

P.O. Box 6060

Warwick, RI 02887-6060

ASBESTOS INSPECTION REPORT

This Asbestos Inspection Summary Report is being submitted to Mr. John O'Burka [Director of Plant Operations - Foster-Glocester Regional Public Schools] based on "suspect" asbestos containing building materials (ACM) that and may be impacted as a result of the upcoming scheduled renovation work this upcoming Summer of 2017 to include:

SCHOOL BUILDING: **Fogarty Memorial Elementary School**
736 Snake Hill Road
Glocester, RI

REPORT DATE: June 20, 2017

INSPECTION RESULTS:

CEILING TILES: The 2' x 2' and the 2' x 4' suspended ceiling tiles located throughout this building **do not contain asbestos.**

PLASTER WALLS & CEILINGS: The gypsum/joint compound covered walls/ceiling scattered throughout this building **do not contain asbestos.**

PIPE INSULATION - there is **no ACM** thermal covering/insulation (only fiberglass insulation) covering the pipes and fittings [tees, elbows, unions, etc.] within accessible areas throughout the school building.

DOORWAY WALL CAULKING - the caulking material around the entry doorway frames (scheduled to be replaced) **does not contain asbestos.**

DOOR/WINDOW PANELS - the entry doorway / window panels (scheduled to be replaced) is comprised of slate board material [**non-ACM**].

Refer to the attached SanAir Tech Lab Report (pages #3 - #4) for sample confirmation.

RECORDKEEPING - Insert copies of this report into the applicable Schools Management Planner Booklets (school and office areas).

**INSPECTION
PERFORMED BY:**

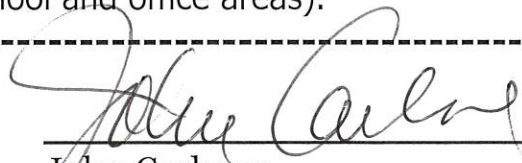

John Carbone
(RI Asbestos Inspector & Project Designer #177)

SanAir Technologies Laboratory

Analysis Report

prepared for

**Vortex Inc. Enviro. Management
Consulting Training**

Report Date: 6/20/2017
Project Name: Fogarty
Project #: 17-231
SanAir ID#: 17022671



NVLAP LAB CODE 200870-0



Certification # 652931



License # LAB0166



804.897.1177

www.sanair.com



SanAir Technologies Laboratory, Inc.

1551 Oakbridge Drive, Suite B, Powhatan, VA 23139
804.897.1177 Toll Free: 888.895.1177 Fax: 804.897.0070
Web: <http://www.sanair.com> E-mail: iaq@sanair.com

Vortex Inc. Enviro. Management Consulting Training
PO Box 6060
Warwick, RI 02887

June 20, 2017

SanAir ID # 17022671
Project Name: Fogarty
Project Number: 17-231

Dear John Carbone,

We at SanAir would like to thank you for the work you recently submitted. The 11 sample(s) were received on Monday, June 19, 2017 via FedEx. The final report(s) is enclosed for the following sample(s): 1, 2, 3, 4, 5, 6, 7, 8, 9, 10, 11.

These results only pertain to this job and should not be used in the interpretation of any other job. This report is only complete in its entirety. Refer to the listing below of the pages included in a complete final report.

Sincerely,

Sandra Sobrino
Asbestos & Materials Laboratory Manager
SanAir Technologies Laboratory

Final Report Includes:

- Cover Letter
- Analysis Pages
- Disclaimers and Additional Information

sample conditions:

11 sample(s) in Good condition



SanAir Technologies Laboratory, Inc.

1551 Oakbridge Drive, Suite B, Powhatan, VA 23139
804.897.1177 Toll Free: 888.895.1177 Fax: 804.897.0070
Web: <http://www.sanair.com> E-mail: iaq@sanair.com

SanAir ID Number

17022671

FINAL REPORT

Name: Vortex Inc. Enviro. Management Consulting
Address: Training
PO Box 6060
Warwick, RI 02887

Project Number: 17-231
P.O. Number:
Project Name: Fogarty

Collected Date: Not Provided on COC
Received Date: 6/19/2017 11:55:00 AM
Report Date: 6/20/2017 11:56:36 AM
Analyst: Robertson, Erin

Asbestos Bulk PLM EPA 600/R-93/116

SanAir ID / Description	Stereoscopic Appearance	% Fibrous	Components		Asbestos Fibers
			% Non-Fibrous		
1 / 17022671-001 J.C	White Non-Fibrous Homogeneous		100%	Other	None Detected
2 / 17022671-002 J.C.	White Non-Fibrous Homogeneous		100%	Other	None Detected
3 / 17022671-003 J.C	White Non-Fibrous Homogeneous		100%	Other	None Detected
4 / 17022671-004 2x2 C.T	White Fibrous Homogeneous	45% 40%	Min. Wool Cellulose	15% Other	None Detected
5 / 17022671-005 2x2 C.T	White Fibrous Homogeneous	45% 40%	Min. Wool Cellulose	15% Other	None Detected
6 / 17022671-006 2x2 C.T	White Fibrous Homogeneous	45% 40%	Min. Wool Cellulose	15% Other	None Detected
7 / 17022671-007 2x4 CT	White Fibrous Homogeneous	45% 40%	Min. Wool Cellulose	15% Other	None Detected

Certification

Analyst: *Erin Robertson*
Analysis Date: 6/19/2017

Approved Signatory: *[Signature]*
Date: 6/20/2017



SanAir Technologies Laboratory, Inc.

1551 Oakbridge Drive, Suite B, Powhatan, VA 23139
804.897.1177 Toll Free: 888.895.1177 Fax: 804.897.0070
Web: <http://www.sanair.com> E-mail: iaq@sanair.com

SanAir ID Number

17022671

FINAL REPORT

Name: Vortex Inc. Enviro. Management Consulting
Address: Training
PO Box 6060
Warwick, RI 02887

Project Number: 17-231
P.O. Number:
Project Name: Fogarty

Collected Date: Not Provided on COC
Received Date: 6/19/2017 11:55:00 AM
Report Date: 6/20/2017 11:56:36 AM
Analyst: Robertson, Erin

Asbestos Bulk PLM EPA 600/R-93/116

SanAir ID / Description	Stereoscopic Appearance	Components		Asbestos Fibers
		% Fibrous	% Non-Fibrous	
8 / 17022671-008 2x4 CT	White Fibrous Homogeneous	45% Min. Wool 40% Cellulose	15% Other	None Detected
9 / 17022671-009 2x4 CT	White Fibrous Homogeneous	45% Min. Wool 40% Cellulose	15% Other	None Detected
10 / 17022671-010 Door/ W Caulking	Brown Non-Fibrous Homogeneous		100% Other	None Detected
11 / 17022671-011 Door/ W Caulking	Brown Non-Fibrous Homogeneous		100% Other	None Detected

Certification

Analyst: *Erin Robertson*
Analysis Date: 6/19/2017

Approved Signatory: *[Signature]*
Date: 6/20/2017

Disclaimer

The final report cannot be reproduced, except in full, without written authorization from SanAir. Fibers smaller than 5 microns cannot be seen with this method due to scope limitations. The accuracy of the results is dependent upon the client's sampling procedure and information provided to the laboratory by the client. SanAir assumes no responsibility for the sampling procedure and will provide evaluation reports based solely on the sample and information provided by the client. This report may not be used by the client to claim product endorsement by NVLAP or any other agency of the U.S. government.

For NY state samples, method EPA 600/M4-82-020 is performed.

Polarized- light microscopy is not consistently reliable in detecting asbestos in floor covering and similar non-friable organically bound materials. Quantitative transmission electron microscopy is currently the only method that can be used to determine if this material can be considered or treated as non-asbestos containing.

NY ELAP lab ID 11983



1551 Oakbridge Dr. STE B
 Powhatan, VA 23139
 804.897.1177 / 888.895.1177
 Fax 804.897.0070
 sanair.com

Asbestos
 Chain of Custody
 Form 140, Rev 1, 1/20/2017

SanAir ID Number
 17022671

Company: Vortex Inc. Enviro. Management Consulting Training # 17-231	Collect by: J CARBONE
Address: PO Box 6060	Project Name: FOGARTY
City, St., Zip: Warwick, RI 02887	Date Collected:
State of Collection: RI Account#: 3042	P.O. Number:
Email: vortex@fogmail.com	

Bulk		Air		Soil	
ABB	PLM EPA 600/R-93/116 <input checked="" type="checkbox"/>	ABA	PCM NIOSH 7400 <input type="checkbox"/>	ABSE	PLM EPA 600/R-93/116 (Qual.) <input type="checkbox"/>
1-3.6	7-9 Positive Stop <input checked="" type="checkbox"/>	ABA-2	OSHA w/ TWA* <input type="checkbox"/>	Vermiculite & Soil	
ABEPA	PLM EPA 400 Point Count <input type="checkbox"/>	ABTEM	TEM AHERA <input type="checkbox"/>	ABSP	PLM CARB 435 (LOD <1%) <input type="checkbox"/>
ABB1K	PLM EPA 1000 Point Count <input type="checkbox"/>	ABATN	TEM NIOSH 7402 <input type="checkbox"/>	ABSP1	PLM CARB 435 (LOD 0.25%) <input type="checkbox"/>
ABBEN	PLM EPA NOB** <input type="checkbox"/>	ABT2	TEM Level II <input type="checkbox"/>	ABSP2	PLM CARB 435 (LOD 0.1%) <input type="checkbox"/>
ABBCH	TEM Chatfield** <input type="checkbox"/>	Other:	<input type="checkbox"/>	Dust	
ABBTM	TEM EPA NOB** <input type="checkbox"/>	New York ELAP		ABWA	TEM Wipe ASTM D-6480 <input type="checkbox"/>
ABQ	PLM Qualitative <input type="checkbox"/>	PLM NY	PLM EPA 600/M4-82-020 <input type="checkbox"/>	ABDMV	TEM Microvac ASTM D-5755 <input type="checkbox"/>
		ABEPA2	NY ELAP 198.1 <input type="checkbox"/>	Matrix Other	
Water		ABENY	NY ELAP 198.6 PLM NOB <input type="checkbox"/>		
ABHE	EPA 100.2 <input type="checkbox"/>	ABBNY	NY ELAP 198.4 TEM NOB <input type="checkbox"/>		

** Available on 24-hr. to 5-day TAT

Turn Around Times	3 HR (4 HR TEM) <input type="checkbox"/>	6 HR (8HR TEM) <input type="checkbox"/>	12 HR <input type="checkbox"/>	24 HR <input checked="" type="checkbox"/>
	<input type="checkbox"/> 2 Days	<input type="checkbox"/> 3 Days	<input type="checkbox"/> 4 Days	<input type="checkbox"/> 5 Days

Special Instructions

Sample #	Sample Identification/Location	Volume or Area	Sample Date	Flow Rate*	Start - Stop Time*
1	J.C				
2	J.C				
3	J.C				
4	ZXZ C.T				
5	"				
6	"				
7	ZX4 CT				
8	"				
9	"				
10	Door / w CAULKING				
11					

Relinquished by	Date	Time	Received by	Date	Time
J. Carbone			MC	JUN 19 2017	11:55AM

If no technician is provided, then the primary contact for your account will be selected. Unless scheduled, the turnaround time for all samples received after 3 pm EST Friday will begin at 8 am Monday morning. Weekend or holiday work must be scheduled ahead of time and is charged for rush turnaround time. SanAir covers Standard Overnight FedEx shipping. Shipments billed to SanAir with a faster shipping rate will result in additional charges.

Page 1 of 1



VORTEX INC.

ENVIRONMENTAL MANAGEMENT • CONSULTING • TRAINING
MAILING ADDRESS: P.O. BOX 6060 • WARWICK, RI 02887-6060

**Rhode Island Department of Health
Asbestos Program
Asbestos Inspector**

JOHN CARBONE

Exp. Date: **03/31/2018**
License #: **AAC-0177**
Member of C.O.N.E.S.



**Rhode Island Department of Health
Asbestos Program
Asbestos Management Planner**

JOHN CARBONE

Exp. Date: **03/31/2018**
License #: **AAC-0177**
Member of C.O.N.E.S.



**Rhode Island Department of Health
Asbestos Program
Asbestos Project Designer**

JOHN CARBONE

Exp. Date: **03/31/2018**
License #: **AAC-0177**
Member of C.O.N.E.S.



TRAINING CENTER: 3670 West Shore Road - Suite #1 • Warwick, RI 02886 • FAX (401) 738-7869
(401) 738-7710 • 1-800-VORTEXX • WWW.1800VORTEXX.COM

"Celebrating 25 years of Services"



**FOGARTY MEMORIAL SCHOOL
Boilers Replacement
North Scituate, Rhode Island**

AA23018

**DOCUMENT 00 41 02
BID FORM – Addendum #1**

Date: _____

To: **Finance Director**
Glocester Town Hall
1145 Putnam Pike
Chepachet, Rhode Island 02814

Project: Boilers Replacement at **Fogarty Memorial School**
736 Snake Hill Road
North Scituate, Rhode Island 02857

Submitted By: _____

(Include in the above spaces, the firm’s legal name, address, telephone and fax numbers, contact and e-mail address. All information should be typed or printed)

NOTE: The Owner’s Selection Criteria shall determine the lowest evaluated or responsive Bid.

1. BASE BID

Having thoroughly examined the Project Site and all matters referred to in the Information for Bidders and in the Bid, Documents prepared by Aharonian & Associate, Inc., Architects for the above referenced Project, we, the undersigned, hereby offer to enter into a Contract to perform the Work for the sum of:

\$,				,				.		
----	--	--	---	--	--	--	---	--	--	--	---	--	--

(Numeric)

\$ _____ Dollars
(Written)

In case of discrepancy, the amount shown in words shall govern. Failure to fill out the above item, if providing a Base Bid, will establish the Bid as non-responsive.

WE HAVE INCLUDED THE 5% BID SURETY AS REQUIRED BY THE INVITATION FOR BIDS.

2. ADDENDA

The following Addenda have been received. The modifications to the Bid Documents noted therein have been considered and all costs thereto are included in the Bid Sum.

Addendum #____Dated _____ Addendum #____Dated _____

Addendum #____Dated _____ Addendum #____Dated _____

3. BASE BID BREAKOUT COSTS

The following line-item costs ARE INCLUDED IN THE BASE BID amount and are broken out for use by the Owner.

- A. Include list of all Subcontractors with Schedule of Values

4. BID ALTERNATES

The following Bid Alternates may be accepted or rejected by the Owner as deemed in the best interest of the Owner without regard to the order of listing or cost of the Alternate. The cost of all Alternates shall be based on the work as described and/or shown in the Contract Documents (Drawings and Project Manual).

ALTERNATE #1: Add/Deduct \$ _____

ALTERNATE #2: Add/Deduct \$ _____

5. SCHEDULE – CONTRACT TIME

If the Bid is accepted, unless otherwise indicated on the Bid Form, Bidder hereby agrees to commence the Work under this Contract within fourteen (14) calendar days after issuance of a written "Notice to Proceed" by the Owner. (NOTE: The successful bidder shall not begin construction until a copy of the Building Permit is submitted to Owner.)

Bidder hereby agrees to achieve Substantial Completion of the Work on or before August 16, 2023, and to achieve Final Completion of the Work on or before August 31, 2023.

6. ADDITIONAL WORK - OVERHEAD AND PROFIT

The Bidder agrees to be bound by the following percentages of cost basis for overhead, supervision, bond and profit and other general expenses for any additional work. If accepted by the Owner in the award of this Contract, these percentages shall be used in establishing the adjustment to the Contract Sum for additions to or deductions from the Work in accordance with the applicable sections of the General Conditions.

- A. To the Contractor for Work performed by its own forces: Maximum ____ percent of the cost.
- B. To Subcontractors for Work performed by its own forces: Maximum ____ percent of the cost.
- C. The combined overhead and profit for Contractor and Subcontractors: Maximum ____ percent of the cost.

7. ALLOWANCES

The above Base Bid Price **INCLUDES** the costs for the following allowances as outlined in Section 012100 "Allowances".

- A. CONTINGENCY ALLOWANCE:

1 Provide a \$10,000.00 allowance for additional scope or for any hazardous material abatement services required during the course of the work as a result of positive hazardous material testing results.

B. INSPECTION AND TESTING ALLOWANCE:

1 Provide a \$2,000.00 allowance for hazardous material testing services and the preparation of an abatement plan as necessary pending testing results.

8. UNIT PRICES

A. If accepted by the Owner in the award of this Contract, Unit Prices shall be used in establishing the adjustment to the Contract Sum for additions to or deductions from the Work in accordance with the applicable sections of the General Conditions. The Unit Prices listed shall include all costs, overhead and profit and no further surcharges are to be added to any Unit Price item of Work that may be done. Work deleted from the Contract will be calculated at 100% of the additional work Unit Prices.

B. Bidder agrees that the Unit Prices will not contain anything to alter or void the Lump Sum Bid submitted herein and that applicable contents of this Bid shall be binding on the Unit Prices and the Work involved whether or not specifically stated.

C. Unit Prices for fabricated items shall include all necessary connections and fastenings required to produce a complete assembly.

D. Unit Price Schedule: No Unit Price requirements are established for the Project.

9. BIDDER ACKNOWLEDGMENTS

A. The Bidder understands that the Owner reserves the right to reject any or all Bids and to waive any formalities in the bidding.

B. The Bidder agrees that this Bid shall be good and may not be withdrawn for a period of sixty (60) calendar days after the scheduled closing time for receiving Bids.

C. Upon written notice of the acceptance of its Bid by the Owner and in accordance with Article 14 of the Information for Bidders, the Bidder shall provide a Certificate of Insurance covering all operations under this Contract. The certificate meeting all conditions set forth therein shall be submitted to the Owner prior to formal execution of the Contract.

D. Upon written notice of the acceptance of its Bid by the Owner, the Bidder shall execute the formal Contract (Document 00 52 00 of the Project Manual) within ten (10) calendar days and deliver to the Owner a Performance Bond and a Payment Bond (Document 00 61 13 of the Project Manual) as required by the General Conditions.

E. The Bid Surety, in the amount of 5% of the Base Bid, is to become the property of the Owner in the event the Contract and Bonds are not executed within the timeframe set forth, as liquidated damages for the delay and additional expense to the Owner caused thereby.

F. By submission of this Bid, the Bidder certifies, and in the case of a joint Bid, each party thereto certifies as to its own organization, that its Bid has been arrived at independently, without consultation, communication or agreement as to any matter relating to this Bid, with any other Bidder or with any competitor.

G. The Foster School Committee reserves the right to waive any informality in any, or in all proposals and reject any and all proposals if deemed to be in their best interest to do so. The Foster School Department reserves the right to negotiate with any or all contractors who submit proposals if it determines that such negotiation is in the best

interest of the School Department and its constituents. The Foster School Department also reserves the right to negotiate an extension of the contract with the successful company that is selected.

10. REQUIREMENT FOR LICENSE NUMBER

A. In compliance with the requirements of Rhode Island General Law, Section 5-65-23, my Rhode Island license number for the Work to be performed by this firm as Prime Contractor is:

LICENSE TYPE: _____ **LICENSE NUMBER:** _____

11. BID FORM SIGNATURE(S)

The undersigned declares: that the only person interested in this proposal as principals are named herein as such; that no official of the Owner and no person acting for or employed by the Owner is interested directly or indirectly in this proposal or any contract which may be made under it or in any expected profits to arise there from; that the proposal is made in good faith, without fraud, collusion or connection with any other person bidding or refraining from bidding for the same work; that the Contract Documents relating to the Contract covered by this proposal and in regard to all conditions pertaining to the Work have been examined and has carefully checked the estimates of cost and from them makes this proposal.

Respectively Submitted,

Name of Firm

SEAL (if Bid is by a corporation)

Signature

Title

Business Address

Telephone Number and Fax Number

The Bidder shall provide an affidavit that the person who has affixed his or her signature to this Bid Form is actively and legally authorized to bind the firm contractually. This affidavit MUST be submitted with and attached to the Bid Form.

END OF DOCUMENT 00 41 02



**FOGARTY MEMORIAL SCHOOL
Boilers Replacement
North Scituate, Rhode Island**

AA23018

**SECTION 01 23 00
ALTERNATES – Addendum #1**

PART 1 GENERAL

1.01 SECTION INCLUDES

- A. Administrative and procedural requirements for alternates.

1.02 RELATED DOCUMENTS AND SECTIONS

- A. Division 00 Documents and Division 01 Sections.

1.03 DEFINITIONS

- A. Alternate: An amount proposed by Bidders and noted on the Bid Form for certain Work defined in the Bidding Requirements that may be added to or deducted from the Base Bid amount if Owner decides to accept a corresponding change either in the amount of construction to be completed or in the products, materials, equipment, systems or installation methods described in the Contract Documents.
 - 1. The cost or credit for each Alternate is the net addition to or deduction from the Contract Sum to incorporate the Alternate into the Work. No other adjustments are made to the Contract Sum.

1.04 PROCEDURES

- A. Coordination: Modify or adjust affected adjacent work as necessary to completely integrate work of the Alternate into Project.
 - 1. Include as part of each Alternate, miscellaneous devices, accessory objects, and similar items incidental to or required for a complete installation whether or not indicated as part of Alternate.
- B. Immediately following award of the Contract, notify each party involved, in writing, of the status of each Alternate. Indicate if Alternates have been accepted, rejected or deferred for later consideration. Include a complete description of negotiated modifications to Alternates.
- C. Execute accepted Alternates under the same conditions as other work of the Contract.
- D. A Schedule of Alternates is included at the end of this Section.

PART 2 PRODUCTS (Not Applicable)

PART 3 EXECUTION

3.01 SCHEDULE OF ALTERNATES

A. Alternate #1: Add/Deduct:

Remove: Removal of abandoned domestic hot water tank from scope, hazmat abatement shall remain in the project scope.

B. Alternate #2: Add/Deduct:

Remove: Provide pricing to change from Modulating Boiler Burners as shown and indicated in the project documents to High-Low Fire Burners.

END OF SECTION 01 23 00



Boiler Replacement
FOGARTY MEMORIAL SCHOOL
North Scituate, Rhode Island 02886

AA# 23018

SECTION 22 07 00
PLUMBING INSULATION

PART 1 - GENERAL

1.01 WORK INCLUDED

- A. Piping insulation.
- B. Jackets and accessories.

1.02 RELATED WORK

- A. Section 22 10 00 - Plumbing Piping.

1.03 QUALITY ASSURANCE

- A. Applicator: Company specializing in piping insulation application with three years minimum experience.
- B. Materials: Flame spread/fuel contributed/smoke developed rating in accordance with NFPA 255 and UL 723. Fiberglass insulation shall have flame spread rating of 25/smoke developed rating of 50; calcium silicate insulation shall have a flame spread rating of 0/smoke developed rating of 0.

PART 2 - PRODUCTS

2.01 INSULATION

- A. Molded pipe insulation shall be manufactured to meet ASTM C 585 for sizes required in the particular system. It shall be of a type suitable for installation on piping systems. Molded fibrous glass pipe insulation shall comply with the requirements of ASTM C 547.
- B. For indoor systems operating at temperatures from zero to +450F: Heavy density Fiberglas pipe insulation with factory applied all-service jacket (ASJ) and Doublesure two component adhesive closure system, rated for a maximum service temperature of 850F. For large pipe sizes where SSL-II is not available, the single adhesive SSL closure may be substituted. Circumferential joints shall be sealed by butt strips having a two-component sealing system. Stapling is not required to complete the closure. When self sealing lap systems are used, sufficient thickness of insulation shall be used to maintain the outer surface temperature of the operating system below +150F. Manufacturer's data regarding thickness constraints in relation to operating temperature shall be followed. When multiple layers are required, all inner layer(s) shall beunjacketed. On cold systems, vapor barrier performance is extremely important. All penetrations of the ASJ and exposed ends of insulation must be sealed with vapor barrier mastic. If humidities in excess of 90% are expected, the ASJ shall be protected with either a mastic coating or a suitable vapor retarding outer jacket. Vapor seals at butt joints shall be applied at every fourth pipe section joint and at each fitting to provide isolation of water incursion.

- C. Fittings and valves shall be insulated with pre-formed fiberglass fittings, fabricated sections of Fiberglas pipe insulation, Fiberglas pipe and tank insulation, Fiberglas blanket insulation, or insulating cement. Thickness shall be equal to adjacent pipe insulation. Finish shall be with pre-formed PVC fitting covers or as otherwise specified on contract drawings. Flanges, couplings and valve bonnets shall be covered with an oversized pipe insulation section sized to provide the same insulation thickness as on the main pipe section. An oversized insulation section shall be used to form a collar between the two insulation sections with low density blanket insulation being used to fill gaps. Jacketing shall match that used on straight pipe sections. Rough cut ends shall be coated with a suitable weather or vapor resistant mastic as dictated by the system location and service. On hot systems where fittings are to be left exposed, insulation ends should be beveled away from bolts for easy access. On cold systems, particular care must be given to vapor sealing the fitting cover or finish to the pipe insulation vapor barrier. All valve stems must be sealed with caulking which allows free movement of the stem but provides a seal against moisture incursion.
- D. All piping shall be supported in such a manner that neither the insulation or the vapor/weather barrier is compromised by the hanger or the effects of the hanger. In all cases, hanger spacing must be such that the circumferential joint may be made outside the hanger. On cold systems, vapor barrier must be continuous, including material covered by the hanger saddle.
- E. Piping systems 3" in diameter or less, insulated with Fiberglas insulation, may be supported by placing saddles of the proper length and spacing, under the insulation.
- F. Thermal expansion and contraction of the piping and insulation system can generally be taken care of by utilizing double layers of insulation and staggering both longitudinal and circumferential joints. Where long runs are encountered, expansion joints may be required where single layers of insulation are being used and should be so noted on the contract drawings.
- G. On vertical runs, insulation support rings shall be used as indicated on contract drawings.

PART 3 - EXECUTION

3.01 SITE INSPECTION

- A. Before starting work under this section, carefully inspect the site and installed work of other trades and verify that such work is complete to the point where installation of materials and accessories under this section can begin.
- B. Verify that all materials and accessories can be installed in accordance with project drawings and specifications and material manufacturers' recommendations.
- C. Verify, by inspecting product labeling, submittal data, and/or certifications which may accompany the shipments, that all materials and accessories to be installed on the project comply with applicable specifications and standards and meet specified thermal and physical properties.

3.02 PREPARATION

- A. Ensure that all pipe and equipment surface over which insulation is to be installed are clean and dry.
- B. Ensure that insulation is clean, dry, and in good mechanical condition with all factory applied vapor or weather barriers intact and undamaged. Wet, dirty, or damaged insulation shall not be acceptable for installation.

3.03 INSTALLATION

- A. Install all insulation materials and accessories in accordance with manufacturer's published instructions and recognized industry practices to ensure that it will serve its intended purpose.

- B. Install insulation on piping subsequent to installation of heat tracing, painting, testing, and acceptance tests.
- C. Install insulation materials with smooth and even surfaces. Insulate each continuous run of piping with full-length units of insulation, with single cut piece to complete run. Do not use cut pieces or scraps abutting each other. Butt insulation joints firmly to ensure complete, tight fit over all piping surfaces.
- D. Maintain the integrity of factory-applied vapor barrier jacketing on all pipe insulation, protecting it against puncture, tears or other damage.
- E. Fittings: Cover valves, fittings, and similar items in each piping system using one of the following: Mitered sections of insulation equivalent in thickness and composition to that installed on straight pipe runs, or Insulation cement equal in thickness to the adjoining insulation, or PVC fitting covers insulated with material equal in thickness and composition to adjoining insulation.
- F. Penetrations: Extend piping insulation without interruption through walls, floors, and similar piping penetrations, except where otherwise specified.
- G. Joints: Butt pipe insulation against hanger inserts. For hot pipes, apply 3" wide vapor barrier tape or band over butt joints. For cold piping apply wet coat of vapor barrier lap cement on butt joints, and seal joints with 3" wide vapor barrier tape or band. All pipe insulation ends shall be tapered and sealed, regardless of service.

3.04 FIELD QUALITY ASSURANCE

- A. Upon completion of all insulation work covered by this specification, visually inspect the work and verify that it has been correctly installed. This may be done while work is in progress, to assure compliance with requirements herein to cover and protect insulation materials during installation.

3.05 PROTECTION

- A. Replace damaged insulation which cannot be satisfactorily repaired, including insulation with vapor barrier damage and moisture-saturated insulation.
- B. The insulation contractor shall advise the general and/or the mechanical contractor as to requirements for protection of the insulation work during the remainder of the construction period, to avoid damage and deterioration of the finished insulation work.

3.06 SAFETY PRECAUTIONS

- A. Insulation contractor's employees shall be properly protected during installation of all insulation. Protection shall include proper attire when handling and applying insulation materials and shall include (but not be limited to) disposable dust respirators, gloves, hard hats, and eye protection.
- B. The insulation contractor shall conduct all jobsite operations in compliance with applicable provisions of the Occupational Safety and Health Act, as well as with all state and/or local safety and health codes and regulations that may apply to the work.

3.07 SCHEDULE

- A. Domestic Hot and Cold Water - use the following thicknesses of insulation:

<u>Pipe Size</u>	<u>Insulation Thickness</u>
Runouts (to 1-1/4")	1 inch
1-1/2" to 4"	1-1/2 inch

- B. Condensate Waste Piping, Exposed Copper Waste Piping, Exterior Gas Piping, Piping Concealed

Within Concrete Block Walls or Buried Within Floor Slab - use 1/2 inch thick insulation for all pipe sizes.

END OF SECTION 22 07 00



Boiler Replacement
FOGARTY MEMORIAL SCHOOL
North Scituate, Rhode Island 02886

AA# 23018

SECTION 22 10 00
PLUMBING PIPING

PART 1 GENERAL

1.01 WORK INCLUDED

- A. Pipe and pipe fittings.
- B. Valves.
- C. Domestic water piping system.

1.02 RELATED WORK

- A. Section 22 07 00 - Piping Insulation.
- B. Section 22 40 00 - Plumbing Fixtures.

1.03 QUALITY ASSURANCE

- A. Valves: Manufacturer's name and pressure rating marked on valve body. All valves shall be totally lead-free.
- B. Fittings: All domestic water piping fittings shall be totally lead-free.
- C. Welding Materials and Procedures: Conform to ASME Code and applicable state labor regulations.
- D. Welders Certification: In accordance with ANSI/ASME Sec 9.

1.04 DELIVERY, STORAGE, AND HANDLING

- A. Deliver products to site.
- B. Store and protect products.
- C. Deliver and store valves in shipping containers with labelling in place.

PART 2 PRODUCTS

2.01 WATER PIPING AND CONDENSATE WASTE PIPING, ABOVE GRADE

- A. Copper Tubing: ASTM B88, Type L, hard drawn. Fittings: ANSI/ASME B16.29, wrought copper. Joints: Use lead-free solder on all joints.
- B. Copper Tubing: ASTM B88, Type K, hard drawn. Fittings: ANSI/ASME B16.29, wrought copper. Joints: Use lead-free solder on all joints. Use one-piece Type K copper for water piping installed within concrete block walls.

- C. CPVC Pipe and Fittings: Schedule 40 / Schedule 80 pipe and fittings shall be manufactured from a Type IV, Grade I Chlorinated Polyvinyl Chloride (CPVC) compound with a Cell Classification of 23447 per ASTM D1784. The pipe shall be manufactured in strict compliance to ASTM F441, consistently meeting the quality assurance test requirements of this standard with regard to material, workmanship, burst pressure, flattening, and extrusion quality. The pipe shall be produced in the USA using domestic materials, by an ISO 9001 certified manufacturer, and shall be stored indoors after production, at the manufacturing site, until shipped from factory. This pipe shall carry the National Sanitation Foundation (NSF) seal of approval for potable water applications.

2.02 FLANGES, UNIONS, AND COUPLINGS

- A. Pipe Size 2 Inches and Under: 150 psig malleable iron unions for threaded ferrous piping; lead-free bronze unions for copper pipe, soldered joints.
- B. Pipe Size Over 2 Inches: 150 psig forged steel slip-on flanges for ferrous piping; lead-free bronze flanges for copper piping; neoprene gaskets for gas service; 1/16 inch thick preformed neoprene bonded to asbestos.
- C. Grooved and Shouldered Pipe End Couplings: Malleable iron housing clamps to engage and lock, designed to permit some angular deflection, contraction, and expansion; "C" shape composition sealing gasket; steel bolts, nuts, and washers; galvanized couplings for galvanized pipe.
- D. Dielectric Connections: Union with galvanized or plated steel threaded end, copper solder end, water impervious isolation barrier.

2.03 GLOBE VALVES

- A. Up to 2 Inches: Bronze body, bronze trim, rising stem and handwheel, inside screw, renewable composition disc, solder or screwed ends, with backseating capacity.
- B. Over 2 Inches: Iron body, bronze trim, rising stem, handwheel, OS&Y, plug-type disc, flanged ends, renewable seat and disc.

2.04 BALL VALVES

- A. Up to 2 Inches: Bronze one piece body, stainless steel ball, teflon seats and stuffing box ring, lever handle, and balancing stops where required or shown on drawings, solder or threaded ends.
- B. Over 2 Inches: Cast steel body, chrome plated steel ball, teflon seat and stuffing box seals, lever handle, flanged.

2.05 SWING CHECK VALVES

- A. Up to 2 Inches: Bronze 45 degree swing disc, solder or screwed ends.
- B. Over 2 Inches: Iron body, bronze trim, 45 degree swing disc, renewable disc and seat, flanged ends.

2.06 RELIEF VALVES

- A. Bronze body, teflon seat, steel stem and springs, automatic, direct pressure actuated, capacities ASME certified and labelled.

PART 3 EXECUTION

3.01 PREPARATION

- A. Ream pipe and tube ends. Remove burrs. Bevel plain end ferrous pipe.

- B. Remove scale, oil and dirt, on inside and outside, before assembly.
- C. Prepare piping connections to equipment with flanges or unions.

3.02 INSTALLATION

- A. Provide non-conducting dielectric connections wherever jointing dissimilar metals.
- B. Route piping in orderly manner and maintain gradient.
- C. Install piping to conserve building space and not interfere with use of space.
- D. Group piping whenever practical at common elevations.
- E. Install piping to allow for expansion and contraction without stressing pipe, joints, or connected equipment.
- F. Provide clearance for installation of insulation and access to valves and fittings.
- G. Provide access where valves and fittings are not exposed.
- H. Slope water piping and arrange to drain at low points.
- I. Where pipe support members are welded to structural building framing, scrape, brush clean, and apply one coat of zinc rich primer to welding.
- J. Prepare pipe, fittings, supports, and accessories not prefinished, ready for finish painting.
- K. Install valves with stems upright or horizontal, not inverted.
- L. Provide one plug cock wrench for every ten plug cocks sized 2 inches and smaller, minimum of one. Provide each plug cock sized 2-1/2 inches and larger with a wrench with set screw.
- M. Use lead-free solder and flux for all domestic hot and cold water piping joint connections.
- N. Use Type K, one-piece copper piping insulated with 1/2 inch thick flexible closed-cell polyethylene insulation for all water piping which is installed within concrete block walls or buried within the floor slab.
- O. Install condensate waste piping from equipment waste connection to outdoors or nearest indirect waste connection, with P-trap at outlet connection on each piece of equipment. Condensate waste piping, with P-traps, shall be provided and installed for all air conditioning equipment with cooling coils, and wherever else required or indicated. Provide cleanouts in condensate waste piping system at all changes in direction greater than 45 degrees and not more than 50 feet apart on horizontal runs of condensate waste piping. Contractor shall be responsible for so locating required cleanouts, although cleanouts have not been explicitly identified on the Drawings due to space limitations.
- P. Install all piping at elevations indicated on Project Drawings. Where no elevations are indicated, install piping as high as possible.

3.03 APPLICATION

- A. Use mechanical couplings and fasteners only in accessible locations. Provide adequate clearances for service.
- B. Install unions downstream of valves and at equipment or apparatus connections.

- C. Install lead-free bronze male adapters each side of valves in copper piped system. Sweat solder adapters to pipe.
- D. Install gate or ball valves for shut-off and to isolate equipment, part of systems, or vertical risers.
- E. Install globe or ball valves for throttling, bypass, or manual flow control services.
- F. Provide spring loaded check valves on discharge of water pumps.

3.04 DISINFECTION OF DOMESTIC WATER PIPING SYSTEM

- A. Prior to starting work, verify system is complete, flushed and clean.
- B. Ensure PH of water to be treated is between 7.4 and 7.6 by adding alkali (caustic soda or soda ash) or acid (hydrochloric).
- C. The complete piping system, or parts thereof, shall be filled with a water/chlorine solution containing at least 50 mg/l (ppm) of chlorine, and then the piping system, or parts thereof, shall be valved off and allowed to stand for 24 hours.
- D. Bleed water from outlets and flush system with clean potable water until chlorine does not remain in the water coming from the system.
- E. Take samples no sooner than 24 hours after flushing, from 5 percent of outlets and from water entry, and analyze in accordance with methods prescribed by the health authority having jurisdiction. Repeat the entire procedure if it is shown by a bacteriological examination made by the testing authority that contamination is still present in the system.

3.05 SERVICE CONNECTIONS

- A. Connect new to existing water service piping.

END OF SECTION 22 10 00



Boiler Replacement
FOGARTY MEMORIAL SCHOOL
North Scituate, Rhode Island 02886

AA# 23018

SECTION 22 30 00
PLUMBING EQUIPMENT

PART 1 GENERAL

1.01 WORK INCLUDED

- A. Water heaters.

1.02 QUALITY ASSURANCE

- A. Ensure products and installation of specified products are in conformance with recommendations and requirements of the following organizations:
 1. National Sanitation Foundation (NSF).
 2. American Society of Mechanical Engineers (ASME).
 3. National Board of Boiler and Pressure Vessel Inspectors(NBBPVI).
 4. National Electrical Manufacturers' Association (NEMA).
 5. Underwriters Laboratories (UL).

1.03 REGULATORY REQUIREMENTS

- A. Conform to UL 174 requirements for water heaters.
- B. Conform to ANSI/ASME Section 8D for manufacture of pressure vessels for heat exchangers.
- C. Conform to ANSI/NFPA 30 for tanks.

1.04 OPERATION AND MAINTENANCE DATA

- A. Submit operation and maintenance data under provisions of Division 1 Specifications.
- B. Include operation, maintenance, and inspection data, replacement part numbers and availability, and service depot location and telephone number.

1.05 DELIVERY, STORAGE, AND HANDLING

- A. Deliver products to site under provisions of Division 1 Specifications.
- B. Provide temporary inlet and outlet caps. Maintain caps in place until installation.

1.06 WARRANTY

- A. Provide one year manufacturer's warranty.
- B. Warranty: Include coverage of domestic water heaters.

PART 2 PRODUCTS

2.01 COMMERCIAL ELECTRIC WATER HEATERS

- A. Automatic, vertical storage type, 150 psig maximum working pressure. Capacities and ratings shall be as indicated on the Project Drawings, or as noted below:
- B. Glass lined welded steel tank, with tank inspection port, thermally insulated with rigid polyurethane foam insulation, encased in corrosion-resistant steel jacket; baked-on enamel finish; floor shield and legs.
- C. Surface-mounted thermostat, brass water connections, drain valve, high-density magnesium anode, and ASME rated temperature and pressure relief valve.
- D. Unit approved by UL as automatic storage water heater.
- E. Automatic direct immersion thermostat with adjustable temperature range, minimum 175 degrees F differential, integral manual reset high temperature limiting thermostat, factory set at 205 degrees F.

PART 3 EXECUTION

3.01 WATER HEATER INSTALLATION

- A. Install water heaters in accordance with manufacturer's instructions and to UL requirements.
- B. Coordinate with plumbing piping and related electrical work to achieve operating system.
- C. Install storage tanks in accordance with manufacturer's instructions.
- D. Provide angle legs or skirt support for tanks independent of building structural framing members.
- E. Clean and flush tank after installation. Seal until pipe connections are made.
- F. Apply insulation as close as possible to storage tank by grooving, scoring, and beveling insulation, if necessary. Secure insulation to tank with studs, pins, clips, adhesive, wires, or bands. Fill joints, cracks, seams, and depressions with bedding compound to form smooth surface. Cover insulation with metal mesh and finish with heavy coat of insulating cement. Do not insulate over nameplate or ASME stamps. Bevel and seal insulation around such.
- G. Contractor shall provide all control devices and wiring, as required, to put each water heater in proper operational mode.

END OF SECTION 23 30 00



Boiler Replacement

FOGARTY MEMORIAL SCHOOL

North Scituate, Rhode Island 02886

AA# 23018

SECTION 23 03 00

BASIC MECHANICAL REQUIREMENTS

PART 1 GENERAL

1.01 SECTION INCLUDES

- A. Basic Mechanical Requirements specifically applicable to Division 23 Sections, in addition to Division 1 - General Requirements.

1.02 WORK SEQUENCE

- A. Install work in phases to accommodate Owner's occupancy requirements during the construction period. Coordinate mechanical schedule and operations with Architect/Engineer.

1.03 ALTERNATES

- A. Alternates quoted on Bid Forms will be reviewed and accepted or rejected at the Owner's option. Accepted Alternates will be identified in Owner-Contractor Agreement.
- B. Coordinate related work and modify surrounding work as required.
- C. Schedule of Alternates - see Division 1 Specifications.

1.04 SUBMITTALS

- A. Submit under provisions of Division 1 Specifications. Provide submittals, including specifications, design data, and calculations (as required) for all equipment and materials relating to Division 23 Specifications which are proposed for use on the project. No work will be allowed to proceed until the Architect/Engineer's submittal review is completed.
- B. Submit shop drawings and product data grouped to include complete submittals of related systems, products, and accessories in a single submittal.
- C. Mark dimensions and values in units to match those specified.
- D. Products which are submitted for use on the Project must be equal in quality, performance and serviceability to the products as shown on the Project Drawings and Specifications, including any accessories as noted or specified. It shall be the mechanical contractor's responsibility to verify product equality to the Architect/Engineer's satisfaction before substitution of products will be allowed. If requested, the contractor shall furnish samples of any submitted equipment and materials for general inspection to check for conformity with the requirements of the Specifications.
- E. Where the contractor proposes to use items and equipment other than those specified and/or detailed on the Project Drawings, which may require any redesign of the structure, partitions, foundation, piping, wiring, or any other parts of the mechanical, electrical, and/or architectural layouts, all such required redesign, including new drawings and detailing necessary, shall be prepared by the contractor at the contractor's expense, and shall be approved by the Architect/Engineer.
- F. The mechanical contractor shall prepare and submit As-Built drawings of all systems and equipment at the completion of all systems installation. These drawings shall be provided to the

Architect/Engineer for review and approval. Any deviations from the original Project Drawings shall be so noted.

- G. If requested, the mechanical contractor shall submit a schedule of values, reflecting reasonable and true line item costs, to the Architect/Engineer as part of the Project records. This schedule of values will be submitted prior to the start of construction.

1.05 REGULATORY REQUIREMENTS

- A. Obtain permits, and request inspections from authorities having jurisdiction. All permits, inclusive of their associated costs, are the responsibility of the contractor who performs the related work. The contractor shall verify availability of utility services, including water and natural gas pressures required, invert elevations for connection to sanitary waste systems, etc., and obtain authorization and approval from the respective utility for connections as required for this Project. Any fees required by the respective utilities for installation and connection to these services shall be the responsibility of the contractor. Satisfactory proof of final inspection and approval by all authorities having jurisdiction shall be presented to the Architect/Engineer before work is accepted.

- B. All materials and equipment shall be designed, constructed, installed and tested in strict accordance with these specifications and the latest editions of all of the following applicable standards:

Rhode Island State Building Code	RISBC
National Environmental System Contractors Assoc.	NESCA
American Society of Mechanical Engineers	ASME
American Society of Testing Materials	ASTM
National Electric Code	NEC
National Fire Code	NFC
National Fire Protection Association	NFPA
Underwriters Laboratories, Inc.	UL
National Electrical Manufacturers Association	NEMA
Occupational Health and Safety Act	OSHA
Air Conditioning and Refrigeration Inst.	ARI
Air Moving and Conditioning Association	AMCA
American Society of Heating, Refrigeration and Air Conditioning Engineers	ASHRAE
Environmental Protection Agency	EPA
Building Officials Conference of America	BOCA
Federal Construction Safety Standards	FCSS
American Gas Association	AGA
Sheet Metal and Air Conditioning Contractors National Association	SMACNA
All applicable local ordinances and codes	

- C. The above listed codes and standards shall be followed as minimum requirements and shall not relieve the mechanical contractor from any additional requirements as indicated on the Project Drawings or as herein specified. Where provisions of pertinent codes and standards conflict with Division 23 Specifications, the more stringent provisions shall govern and shall be conformed to.
- D. Any materials or workmanship called for in the above referenced requirements not specified or shown on the Drawings shall be furnished and installed by the contractor as though same had been specifically indicated or mentioned. Any work installed in conflict with these requirements shall become the sole responsibility of the contractor, who shall assume the expense to rectify the installation to the Architect/Engineer's satisfaction.
- E. The contractor shall notify the Architect/Engineer of any deviations from the above referenced requirements pertaining to work indicated or specified before the installation of this work is affected.
- F. The contractor is strongly urged to visit jobsite and review existing conditions which may affect contractor's work, prior to submission of bid. Contractor shall be advised that no extra

compensation will be provided for any additional work required to be done to provide complete functional systems, if a site review would have identified the necessity for the additional work. This condition will be strictly conformed to, even if all required work is not explicitly indicated on the Project Drawings.

1.06 PROJECT/SITE CONDITIONS

- A. Install Work in locations shown on Drawings, unless prevented by Project conditions. As the drawings are diagrammatic and approximate, unless fixed by dimensions, actual field conditions shall govern the exact location of ductwork and piping installation locations. Do not scale Drawings for exact locations. Maintain all required clearances from and around all new and existing mechanical and electrical equipment and apparatus, as noted in equipment or apparatus manufacturer's installation requirements or applicable standards and codes.
- B. Prepare drawings showing proposed rearrangement of Work to meet Project conditions, including changes to Work specified in other Sections. Obtain permission of Architect/Engineer before proceeding. No additional compensation will be allowed for these changes as required by Project conditions.
- C. It shall be the contractor's responsibility to review all Project Drawings which may affect the location of any equipment and apparatus installation locations and/or permit full coordination of work with other trades. The right to make any reasonable change in location of apparatus and equipment up to the time of rough-in is reserved by the Architect/Engineer. Such changes shall be made without additional expense to the Owner.

1.07 SEQUENCING AND SCHEDULING

- A. Construct Work in sequence under provisions of Division 1 Specifications.

1.08 TESTING, ADJUSTING AND BALANCING

- A. The general contractor shall be responsible for providing the services of an AABC or NEBB certified testing, adjusting and balancing firm. This balancing firm shall be responsible for testing, adjusting and balancing all systems and equipment to the satisfaction of the Architect/Engineer. This work shall be performed by a firm that is not directly or indirectly employed by the mechanical contractor.
- B. All required tests shall be made in the presence of the Architect/Engineer, or their representatives.

1.09 SPECIFIC REQUIREMENTS

- A. Only the latest editions and revisions of standards and codes referenced in Division 23 Specifications shall apply to the work.
- B. The Specifications and Project Drawings are complementary, one to the other. Any items mentioned or called for by one shall be considered as being indicated in both the Specifications and the Project Drawings.
- C. The contractor shall provide all labor, materials, tools and equipment required for complete and satisfactory installation.
- D. All materials and equipment shall be delivered to the job site wrapped in protective covering, and shall be stored in a clean, dry location free from dust and water, in such a manner to permit easy access for inspection and handling. Damaged items shall be replaced at no additional cost to the Owner. Any items subject to moisture or condensation shall be completely replaced at no additional cost to the Owner.
- E. The mechanical contractor shall be responsible for providing starters and disconnects for all equipment specified under Division 15 Specifications, unless explicitly stated otherwise. Starters

shall be Cutler Hammer or equal with push buttons, HAND-OFF-AUTO switches, overload and low voltage protection, and auxiliary contacts as required by operational sequences. Starters for three-phase motors shall be magnetic type, unless stated otherwise. When automatic or interlocking control of single phase motors is required, provide with magnetic starters. Starters for two-speed motors shall be two-speed consequent pole type, with decelerating time delay relay for 30 second delay when switching from high to low speed. Manually controlled single-phase motors shall be provided with two-pole manual thermal switch. Starters and disconnects for outdoor use shall be of weatherproof type (NEMA Type 3R).

1.10 DEFINITIONS

- A. "Contractor" means specifically sub-contractor working under his respective section of specifications.
- B. "Furnish" and/or "Provide" means to supply, erect, install and connect up complete in readiness for regular operation, particular work referred to, unless otherwise specified.
- C. "Piping" includes in addition to pipe, all fittings, valves, hangers and other accessories relating to such piping.
- D. "Ductwork" includes in addition to pipe, all fittings, valves, hangers and other accessories relating to such piping.
- E. "Concealed" means hidden from view, in chases, walls or underground.
- F. "Exposed" means not installed underground, or concealed as defined above.
- G. "Supply" means purchase and delivery of material to the site.
- H. "Install" means to erect in place the supplied item.

1.11 GUARANTEE

- A. The mechanical contractor shall guarantee, in writing, the quality of all materials, equipment and workmanship furnished and installed by the mechanical contractor for a period of one year from the date of final acceptance of this installation by the Owner, and shall replace any defective apparatus, material and equipment at the mechanical contractor's expense. This guarantee shall be endorsed and shall be submitted to the Owner by the General Contractor.

PART 2 PRODUCTS (NOT USED)

PART 3 EXECUTION (NOT USED)

END OF SECTION 23 03 00



Boiler Replacement

FOGARTY MEMORIAL SCHOOL

North Scituate, Rhode Island 02886

AA# 23018

SECTION 23 05 93

TESTING, ADJUSTING AND BALANCING

PART 1 GENERAL

1.01 SECTION INCLUDES

- A. Testing, adjustment, and balancing of hydronic systems.
- B. Measurement of final operating condition of HVAC systems.

1.02 REFERENCES

- A. AABC - National Standards for Field Measurement and Instrumentation, Total System Balance.
- B. ASHRAE - 1984 Systems Handbook: Chapter 37, Testing, Adjusting and Balancing.
- C. NEBB - Procedural Standards for Testing, Balancing and Adjusting of Environmental Systems.

1.03 SUBMITTALS

- A. Submit name of adjusting and balancing agency for approval within 30 days after award of Contract.
- B. Submit test reports as a submittal under provisions of Division 1 Specifications.
- C. Prior to commencing work, submit draft reports indicating adjusting, balancing, and equipment data required.
- D. Submit draft copies of report for review prior to final acceptance of Project. Provide final copies for Architect/Engineer and for inclusion in operating and maintenance manuals.
- E. Provide reports in soft cover, letter size, 3-ring binder manuals, complete with index page and indexing tabs, with cover identification at front and side. Include set of reduced drawings with air outlets and equipment identified to correspond with data sheets, and indicating thermostat locations.
- F. Include detailed procedures, agenda, sample report forms prior to commencing system balance.

1.04 REPORT FORMS

- A. Submit reports on AABC National Standards for Total System Balance forms.
- B. Forms shall include the following information:
 - 1. Title Page:
 - a. Company name
 - b. Company address
 - c. Company telephone number
 - d. Project name
 - e. Project location
 - f. Project Architect
 - g. Project Engineer

- h. Project Contractor
- i. Project altitude
- 2. Instrument List:
 - a. Instrument
 - b. Manufacturer
 - c. Model
 - d. Serial number
 - e. Range
 - f. Calibration date
- 3. Electric Motors:
 - a. Manufacturer
 - b. HP/BHP
 - c. Phase, voltage, amperage; nameplate, actual, no load.
 - d. RPM
 - e. Service factor
 - f. Starter size, rating, heater elements
- 4. Pump Data:
 - a. Identification/number
 - b. Manufacturer
 - c. Size/model
 - d. Impeller
 - e. Service
 - f. Design flow rate, pressure drop, BHP
 - g. Actual flow rate, pressure drop, BHP
 - h. Discharge pressure
 - i. Suction pressure
 - j. Total operating head pressure
 - k. Shut off, discharge and suction pressures
 - l. Shut off, total head pressure

1.05 PROJECT RECORD DOCUMENTS

- A. Submit record documents under provisions of Division 1 Specifications.
- B. Accurately record actual locations of balancing valves and rough setting.

1.06 QUALITY ASSURANCE

- A. Agency shall be company specializing in the adjusting and balancing of systems specified in this Section with minimum three years documented experience certified by AABC or NEBB. Perform Work under supervision of Certified Test and Balance Engineer.
- B. Total system balance shall be performed in accordance with AABC National Standards for Field Measurement and Instrumentation, Total System Balance.

1.07 SEQUENCING AND SCHEDULING

- A. Sequence work to commence after completion of systems and schedule completion of work before Substantial Completion of Project.

1.08 PRE-INSTALLATION CONFERENCE

- A. Convene a conference one week prior to commencing work of this Section.

PART 2 PRODUCTS (NOT USED)

PART 3 EXECUTION

3.01 EXAMINATION

- A. Before commencing work, verify that systems are complete and operable.
- B. Report any defects or deficiencies noted during performance of services to Architect/Engineer.
- C. Promptly report abnormal conditions in mechanical systems or conditions which prevent system balance.
- D. If, for design reasons, system cannot be properly balanced, report as soon as observed.
- E. Beginning of work means acceptance of existing conditions.

3.02 PREPARATION

- A. Provide instruments required for testing, adjusting, and balancing operations. Make instruments available to Architect/Engineer to facilitate spot checks during testing.
- B. Provide additional balancing devices as required.

3.03 INSTALLATION TOLERANCES

- A. Adjust hydronic systems to plus or minus 10 percent of design conditions indicated.

3.04 ADJUSTING

- A. Recorded data shall represent actually measured, or observed condition.
- B. Permanently mark settings of valves, dampers, and other adjustment devices allowing settings to be restored. Set and lock memory stops.
- C. After adjustment, take measurements to verify balance has not been disrupted or that such disruption has been rectified.
- D. Leave systems in proper working order, replacing belt guards, closing access doors, closing doors to electrical switch boxes, and restoring thermostats to specified settings.
- E. Check and adjust systems approximately six months after final acceptance and submit report.

3.05 WATER SYSTEM PROCEDURE

- A. Adjust water systems to provide required or design quantities.
- B. Use calibrated Venturi tubes, orifices, or other metered fittings and pressure gages to determine flow rates for system balance. Where flow metering devices are not installed, base flow balance on temperature difference across various heat transfer elements in the system.
- C. Adjust systems to provide specified pressure drops and flows through heat transfer elements prior to thermal testing. Perform balancing by measurement of temperature differential in conjunction with air balancing.
- D. Effect system balance with automatic control valves fully open to heat transfer elements.
- E. Effect adjustment of water distribution systems by means of balancing cocks, valves, and fittings. Do not use service or shut-off valves for balancing unless indexed for balance point.

- F. Where available pump capacity is less than total flow requirements or individual system parts, full flow in one part may be simulated by temporary restriction of flow to other parts.

END OF SECTION 23 05 93



Boiler Replacement

FOGARTY MEMORIAL SCHOOL

North Scituate, Rhode Island 02886

AA# 23018

SECTION 23 07 19

PIPING AND EQUIPMENT INSULATION

PART 1 GENERAL

1.01 WORK INCLUDED

- A. Piping and equipment insulation.
- B. Jackets and accessories.

1.02 RELATED WORK

- A. Section 23 21 13 - Hydronic Piping.
- B. Section 23 51 00 – Breeching, Chimneys and Stacks

1.03 QUALITY ASSURANCE

- A. Applicator: Company specializing in piping insulation application with three years minimum experience.
- B. Materials: Flame spread/fuel contributed/smoke developed rating in accordance with NFPA 255 and UL 723. Fiberglass insulation shall have flame spread rating of 25/smoke developed rating of 50; calcium silicate insulation shall have a flame spread rating of 0/smoke developed rating of 0.

PART 2 PRODUCTS

2.01 PIPING INSULATION

- A. Molded pipe insulation shall be manufactured to meet ASTM C 585 for sizes required in the particular system. It shall be of a type suitable for installation on piping systems. Molded fibrous glass pipe insulation shall comply with the requirements of ASTM C 547.
- B. For indoor systems operating at temperatures from zero to +450F: Heavy density Fiberglass pipe insulation with factory applied all-service jacket (ASJ) and Doublesure two component adhesive closure system, rated for a maximum service temperature of 850F. For large pipe sizes where SSL-II is not available, the single adhesive SSL closure may be substituted. Circumferential joints shall be sealed by butt strips having a two-component sealing system. Stapling is not required to complete the closure. When self sealing lap systems are used, sufficient thickness of insulation shall be used to maintain the outer surface temperature of the operating system below +150F. Manufacturer's data regarding thickness constraints in relation to operating temperature shall be followed. When multiple layers are required, all inner layer(s) shall be unjacketed. On cold systems, vapor barrier performance is extremely important. All penetrations of the ASJ and exposed ends of insulation must be sealed with vapor barrier mastic. If humidities in excess of 90% are expected, the ASJ shall be protected with either a mastic coating or a suitable vapor retarding outer jacket. Vapor seals at butt joints shall be applied at every fourth pipe section joint and at each fitting to provide isolation of water incursion.

- C. Fittings and valves shall be insulated with pre-formed fiberglass fittings, fabricated sections of Fiberglas pipe insulation, Fiberglas pipe and tank insulation, Fiberglas blanket insulation, or insulating cement. Thickness shall be equal to adjacent pipe insulation. Finish shall be with pre-formed PVC fitting covers or as otherwise specified on contract drawings. Flanges, couplings and valve bonnets shall be covered with an oversized pipe insulation section sized to provide the same insulation thickness as on the main pipe section. An oversized insulation section shall be used to form a collar between the two insulation sections with low density blanket insulation being used to fill gaps. Jacketing shall match that used on straight pipe sections. Rough cut ends shall be coated with a suitable weather or vapor resistant mastic as dictated by the system location and service. On hot systems where fittings are to be left exposed, insulation ends should be beveled away from bolts for easy access. On cold systems, particular care must be given to vapor sealing the fitting cover or finish to the pipe insulation vapor barrier. All valve stems must be sealed with caulking which allows free movement of the stem but provides a seal against moisture incursion.
- D. Piping located outdoors and exposed to the weather shall be insulated as indicated above except the thickness shall be determined according to the worst weather extremes expected. The insulation shall then be protected with one of the following weatherproof finishes as indicated on contract drawings:
1. Metal jacketing shall be 0.016" (0.6 mm) minimum aluminum or stainless steel with moisture barrier, secured in accordance with the jacket manufacturer's recommendations. Longitudinal joints shall be applied so they will shed water and shall be sealed completely. Circumferential joints shall be closed using preformed butt strips following manufacturer's recommendations for securement.
 2. UV resistant PVC jacketing may be applied in lieu of metal jacketing provided jacketing manufacturer's limitations with regard to pipe size, surface temperature and thermal expansion and contraction are followed.
 3. Fittings shall be insulated as prescribed above, jacketed with preformed fitting covers matching outer jacketing used on straight pipe sections, with all joints weather sealed.
 4. On outdoor chilled water and refrigerant lines, the insulation system shall be completely vapor sealed before the weather-resistant jacket is applied. The outer jacket shall not compromise the vapor barrier by penetration of fasteners, etc. Vapor stops at butt joints shall be applied at every fourth pipe section joint and at each fitting to provide isolation of water incursion.
- E. All piping shall be supported in such a manner that neither the insulation or the vapor/weather barrier is compromised by the hanger or the effects of the hanger. In all cases, hanger spacing must be such that the circumferential joint may be made outside the hanger. On cold systems, vapor barrier must be continuous, including material covered by the hanger saddle.
- F. Piping systems 3" in diameter or less, insulated with Fiberglas insulation, may be supported by placing saddles of the proper length and spacing, under the insulation.
- G. Thermal expansion and contraction of the piping and insulation system can generally be taken care of by utilizing double layers of insulation and staggering both longitudinal and circumferential joints. Where long runs are encountered, expansion joints may be required where single layers of insulation are being used and should be so noted on the contract drawings.
- H. On vertical runs, insulation support rings shall be used as indicated on contract drawings.

2.02 EQUIPMENT INSULATION

- A. Vessels, tanks, and equipment operating at temperatures up to 450F shall be insulated with glass fiber or calcium silicate insulation selected to conform readily to the surface to which it will be applied. For temperatures over +400F, insulation shall be applied in double layers, staggering the joints of both the insulation and the lagging (if used) wherever practical. Observe manufacturer recommendations on maximum temperature/thickness combinations. Outdoor installations require weather protection of insulation jacketing. Insulation may be one of the following types, depending

on project requirements:

1. Small diameter tanks and vessels with diameters less than 30" in diameter may be insulated with any of the following, depending on the service class required:
 - a. Heavy density Fiberglas pipe insulation, 2" thick, with factory applied all-service jacket (ASJ) and Doublesure two-component adhesive closure system, rated for a maximum service temperature of 850F. For large pipe sizes where SSL-II is not available, the single adhesive SSL closure may be substituted.
 - b. Unjacketed Fiberglas heavy density pipe insulation, 2" thick, rated for maximum operating temperature of 850F may be installed using appropriate banding and then covered with metal or PVC jacketing or otherwise jacketed and/or finished in accordance with details shown.
 - c. Fiberglas pipe and tank insulation, heavy density fiber glass insulation, 3" thick, with end-grain factory applied to ASJ all-service jacket, for systems operating at temperatures to +650F and where moderate abuse resistance is required.
 - d. Calcium Silicate, rigid hydrous asbestos-free calcium silicate insulation, 3" thick, for systems operating at temperatures from +300F to +1200F, where the equipment is expected to be exposed to impact or abuse. The insulation shall be protected from the effects of weather, water, moisture, or mechanical and chemical abuse with either metal or PVC jacketing.
2. Breeching and stacks with diameters less than 30" in diameter shall be insulated with the following:
 - a. Calcium Silicate, rigid hydrous asbestos-free calcium silicate insulation, 3" thick, for systems operating at temperatures from +300F to +1200F, where the equipment is expected to be exposed to impact or abuse. The insulation shall be protected from the effects of weather, water, moisture, or mechanical and chemical abuse with metal or PVC jacketing.
3. If required, boards shall be scored to allow them to conform to curved or irregular surfaces.
4. Mechanical fasteners shall be utilized to hold insulation to surface with bands as required to hold the curvature of the material.
5. Support rings shall be provided to support the top head insulation where required.
6. Outdoor installations require a weather barrier for protection of the insulation jacketing.

PART 3 EXECUTION

3.01 SITE INSPECTION

- A. Before starting work under this section, carefully inspect the site and installed work of other trades and verify that such work is complete to the point where installation of materials and accessories under this section can begin.
- B. Verify that all materials and accessories can be installed in accordance with project drawings and specifications and material manufacturers' recommendations.
- C. Verify, by inspecting product labeling, submittal data, and/or certifications which may accompany the shipments, that all materials and accessories to be installed on the project comply with applicable specifications and standards and meet specified thermal and physical properties.

3.02 PREPARATION

- A. Ensure that all pipe and equipment surfaces over which insulation is to be installed are clean and dry.
- B. Ensure that insulation is clean, dry, and in good mechanical condition with all factory-applied vapor or weather barriers intact and undamaged. Wet, dirty, or damaged insulation shall not be acceptable for installation.
- C. Ensure that pressure testing of piping or duct systems has been completed prior to installing

insulation.

3.03 INSTALLATION

- A. Install all insulation materials and accessories in accordance with manufacturer's published instructions and recognized industry practices to ensure that it will serve its intended purpose.
- B. Install insulation on piping subsequent to installation of heat tracing, painting, testing, and acceptance tests.
- C. Install insulation materials with smooth and even surfaces. Insulate each continuous run of piping with full-length units of insulation, with single cut piece to complete run. Do not use cut pieces or scraps abutting each other. Butt insulation joints firmly to ensure complete, tight fit over all piping surfaces.
- D. Maintain the integrity of factory-applied vapor barrier jacketing on all pipe insulation, protecting it against puncture, tears or other damage.
- E. Fittings: Cover valves, fittings, and similar items in each piping system using one of the following: Mitered sections of insulation equivalent in thickness and composition to that installed on straight pipe runs, or Insulation cement equal in thickness to the adjoining insulation, or PVC fitting covers insulated with material equal in thickness and composition to adjoining insulation.
- F. Penetrations: Extend piping insulation without interruption through walls, floors, and similar piping penetrations, except where otherwise specified.
- G. Joints: Butt pipe insulation against hanger inserts. For hot pipes, apply 3" wide vapor barrier tape or band over butt joints. For cold piping apply wet coat of vapor barrier lap cement on butt joints, and seal joints with 3" wide vapor barrier tape or band. All pipe insulation ends shall be tapered and sealed, regardless of service.
- H. Vertical Piping: All insulated, exposed vertical piping within the building and all insulated piping exposed to the outdoors shall be additionally jacketed with 0.016" thick (minimum) aluminum. Vertical piping shall be protected to a height of 8'-0" above the floor.

3.04 FIELD QUALITY ASSURANCE

- A. Upon completion of all insulation work covered by this specification, visually inspect the work and verify that it has been correctly installed. This may be done while work is in progress, to assure compliance with requirements herein to cover and protect insulation materials during installation.

3.05 PROTECTION

- A. Replace damaged insulation which cannot be satisfactorily repaired, including insulation with vapor barrier damage and moisture-saturated insulation.
- B. The insulation contractor shall advise the general and/or the mechanical contractor as to requirements for protection of the insulation work during the remainder of the construction period, to avoid damage and deterioration of the finished insulation work.

3.06 SAFETY PRECAUTIONS

- A. Insulation contractor's employees shall be properly protected during installation of all insulation. Protection shall include proper attire when handling and applying insulation materials, and shall include (but not be limited to) disposable dust respirators, gloves, hard hats, and eye protection.
- B. The insulation contractor shall conduct all jobsite operations in compliance with applicable provisions of the Occupational Safety and Health Act, as well as with all state and/or local safety

and health codes and regulations that may apply to the work.

3.07 PIPING INSULATION SCHEDULE

- A. Heating Hot Water Piping - use the following thicknesses of insulation:

<u>Pipe Size</u>	<u>Insulation Thickness</u>
Up to 1-1/4"	1-1/2 inch
1-1/2" to 8"	2 inch

3.08 EQUIPMENT INSULATION SCHEDULE

<u>Equipment</u>	<u>Insulation Thickness</u>
Flue Gas Breeching	3 inch
Stacks	3 inch
Boiler and Flue Boxes	2 inch

END OF SECTION 23 07 19



Boiler Replacement

FOGARTY MEMORIAL SCHOOL

North Scituate, Rhode Island 02886

AA# 23018

SECTION 23 21 13

HYDRONIC PIPING

PART 1 GENERAL

1.01 WORK INCLUDED

- A. Pipe and pipe fittings.
- B. Valves.
- C. Heating water and dual-temperature piping system.

1.02 RELATED WORK

- A. Section 23 07 19 - Piping Insulation.
- B. Section 23 21 14 - Hydronic Specialties.

1.03 REGULATORY REQUIREMENTS

- A. Conform to ANSI/ASME B31.9.

1.04 QUALITY ASSURANCE

- A. Valves: Manufacturer's name and pressure rating marked on valve body.
- B. Welding Materials and Procedures: Conform to ANSI/ASME SEC 9 and applicable state labor regulations.

1.05 DELIVERY, STORAGE, AND HANDLING

- A. Deliver products to site under provisions of Division 1 Specifications.
- B. Store and protect products.
- C. Deliver and store valves in shipping containers with labelling in place.

PART 2 PRODUCTS

2.01 HEATING WATER PIPING, ABOVE GROUND

- A. Steel Pipe: ASTM A53 or A120, Schedule 40, 0.375 inch wall for sizes 12 inch and over, black.
 - 1. Fittings: ANSI/ASTM B16.3, malleable iron or ASTM A234, forged steel welding type fittings.
 - 2. Joints: Screwed, or ANSI/AWS D1.1, welded.
- B. Copper Tubing: ASTM B88, Type L, hard drawn.
 - 1. Fittings: ANSI/ASME B16.23 cast brass or ANSI/ASME B16.29 solder wrought copper.
 - 2. Joints: ASTM B32, solder.

2.02 EQUIPMENT DRAINS AND OVERFLOWS

- A. Steel Pipe: ASTM A53 or A120, Schedule 40 galvanized.
 - 1. Fittings: Galvanized cast iron, or ANSI/ASTM B16.3 malleable iron.
 - 2. Joints: Screwed, or grooved mechanical couplings.
- B. Copper Tubing: ASTM B88, Type L, hard drawn.
 - 1. Fittings: ANSI/ASME B16.23 cast brass, or ANSI/ASME B16.29 solder wrought copper.
 - 2. Joints: ASTM B32, solder.

2.03 FLANGES, UNIONS, AND COUPLINGS

- A. Pipe Size 2 Inches and Under: 150 psig malleable iron unions for threaded ferrous piping; bronze unions for copper pipe, soldered joints.
- B. Pipe Size Over 2 Inches: 150 psig forged steel slip-on flanges for ferrous piping; bronze flanges for copper piping; 1/16 inch thick preformed neoprene bonded to asbestos.
- C. Grooved and Shouldered Pipe End Couplings: Malleable iron housing clamps to engage and lock, designed to permit some angular deflection, contraction, and expansion; C-shape elastomer composition sealing gasket for operating temperature range from -30 degrees F to 230 degrees F; steel bolts, nuts, and washers; galvanized couplings for galvanized pipe.

2.04 GLOBE VALVES

- A. Up to 2 Inches: Bronze body, bronze trim, rising stem and handwheel, inside screw, renewable composition disc, solder or screwed ends, with backseating capacity.
- B. Over 2 Inches: Iron body, bronze trim, rising stem, handwheel, OS&Y, plug-type disc, flanged ends, renewable seat and disc.

2.05 BALL VALVES

- A. Up to 2 Inches: Bronze one piece body, stainless steel ball, Teflon seats and stuffing box ring, lever handle, and balancing stops where required or shown on drawings, solder or threaded ends.
- B. Over 2 Inches: Cast steel body, chrome plated steel ball, Teflon seat and stuffing box seals, lever handle, flanged.

2.06 SWING CHECK VALVES

- A. Up to 2 Inches: Bronze 45 degree swing disc, solder or screwed ends.
- B. Over 2 Inches: Iron body, bronze trim, 45 degree swing disc, renewable disc and seat, flanged ends.

2.07 SPRING LOADED CHECK VALVES

- A. Iron body, bronze trim, stainless steel spring, renewable composition disc, screwed, wafer or flanged ends.

2.08 RELIEF VALVES

- A. Bronze body, Teflon seat, stainless steel stem and springs, automatic, direct pressure actuated, capacities ASME certified and labelled.

PART 3 EXECUTION

3.01 PREPARATION

- A. Ream pipe and tube ends. Remove burrs. Bevel plain end ferrous pipe.
- B. Remove scale, oil and dirt on inside and outside before assembly.
- C. Prepare piping connections to equipment with flanges or unions.
- D. After completion, fill, clean, and treat systems.

3.02 INSTALLATION

- A. Route piping in orderly manner, plumb and parallel to building structure, and maintain gradient.
- B. Install piping to conserve building space, and not interfere with use of space and other work.
- C. Group piping whenever practical at common elevations.
- D. Install piping to allow for expansion and contraction without stressing pipe, joints, or connected equipment.
- E. Provide clearance for installation of insulation, and access to valves and fittings.
- F. Provide access where valves and fittings are not exposed.
- G. Slope piping and arrange systems to drain at low points. Use eccentric reducers to maintain top of pipe level.
- H. Where pipe support members are welded to structural building framing, scrape, brush clean, and apply one coat of zinc rich primer to welding.
- I. Prepare pipe, fittings, supports, and accessories for finish painting.
- J. Install valves with stems upright or horizontal, not inverted.
- K. Provide non-conducting dielectric connections wherever joining dissimilar metals.
- L. Use lead-free solder for all copper piping joint connections, where required by authority having jurisdiction.
- M. Install all piping at elevations indicated on Project Drawings. Where no elevations are indicated, install piping as high as possible.

3.03 APPLICATION

- A. Install unions downstream of valves and at equipment or apparatus connections. Automatic control valves shall have unions installed at valve outlet and bypass (three-way control valves only).
- B. Install brass male adapters each side of valves in copper piped system. Sweat solder adapters to pipe.
- C. Install gate, ball or butterfly valves for shut-off and to isolate equipment, part of systems, or vertical risers.
- D. Install ball or globe valves for throttling or bypass services.
- E. Provide spring loaded check valves on discharge of pumps.

- F. Provide 3/4 inch gate or ball drain valves at main shut-off valves, low points of piping, bases of vertical risers, and at equipment.

END OF SECTION 23 21 13



Boiler Replacement

FOGARTY MEMORIAL SCHOOL

North Scituate, Rhode Island 02886

AA# 23018

SECTION 23 21 14

HYDRONIC SPECIALTIES

PART 1 GENERAL

1.01 WORK INCLUDED

- A. Combination fittings.
- B. Balancing valves.

1.02 RELATED WORK

- A. Section 23 21 13 - Hydronic Piping.

1.03 REFERENCES

- A. ANSI/ASME - Boilers and Pressure Vessels Code.

1.04 REGULATORY REQUIREMENTS

- A. Conform to ANSI/ASME Boilers and Pressure Vessels Code Section 8D for manufacture of tanks.

1.05 QUALITY ASSURANCE

- A. Manufacturer: For each product specified, provide components by same manufacturer throughout.

1.06 OPERATION AND MAINTENANCE DATA

- A. Submit operation and maintenance data under provisions of Division 1 Specifications.
- B. Include installation instruction, assembly views, lubrication instructions, and replacement parts list.

1.07 DELIVERY, STORAGE, AND HANDLING

- A. Deliver products to site.
- B. Store and protect products.

PART 2 PRODUCTS

2.01 COMBINATION PUMP DISCHARGE VALVES

- A. Valves: Straight or angle pattern, threaded or flanged cast-iron valve body with bolt-on bonnet for 175 psig operating pressure, non-slam check valve with spring-loaded bronze disc and seat, stainless steel stem, with Schrader valve metering connections with adjustment permitting flow regulation.

2.02 MANUAL BALANCING VALVES (COMBINATION BALANCING/SHUT-OFF VALVES)

- A. Construction: Brass or bronze body, construction to allow valve to function as both a balancing valve and shut-off (service duty) valve, with pipe threads or sweat connections as required, Schrader valve test connections, calibrated nameplate, precision machined orifice, 100% shutoff capability; equal to Taco Circuit-Setter.
- B. Calibration: Control flow within 5 percent of selected rating, over operating pressure range of 10 times minimum pressure required for control.

2.03 RELIEF VALVES

- A. Bronze body, Teflon seat, stainless steel stem and springs, automatic, direct pressure actuated, capacities ASME certified and labelled.

PART 3 EXECUTION

3.01 INSTALLATION AND APPLICATION

- A. Install specialties in accordance with manufacturer's instructions to permit intended performance.
- B. Provide manual air vents at system high points and as indicated.
- C. Provide combination pump discharge valve on discharge side of all pumps or where indicated.
- D. Provide balancing valves on water outlet side of terminal units, coils, etc. or as indicated on the Drawings.

END OF SECTION 23 21 14



Boiler Replacement

FOGARTY MEMORIAL SCHOOL

North Scituate, Rhode Island 02886

AA# 23018

SECTION 23 21 23

HVAC PUMPS

PART 1 GENERAL

1.01 WORK INCLUDED

- A. In-line circulators.

1.02 RELATED WORK

- A. Section 23 07 19 - Piping Insulation.
- B. Section 23 21 13 - Hydronic Piping.
- C. Section 23 21 14 - Hydronic Specialties.

1.03 QUALITY ASSURANCE

- A. Manufacturer: Company specializing in manufacture, assembly, and field performance of pumps with minimum three years experience.

1.04 OPERATION AND MAINTENANCE DATA

- A. Submit operation and maintenance data.
- B. Include installation instructions, assembly views, lubrication instructions, and replacement parts list.

1.05 DELIVERY, STORAGE, AND HANDLING

- A. Deliver products to site.
- B. Store and protect products.

PART 2 PRODUCTS

2.01 ACCEPTABLE MANUFACTURERS

- A. Grundfos.
- B. Bell & Gossett.
- C. Taco.

2.02 GENERAL CONSTRUCTION REQUIREMENTS

- A. Balance: Rotating parts, statically and dynamically.
- B. Construction: To permit servicing without breaking piping or motor connections.

- C. Pump Motors: Operate at 1750 rpm unless specified otherwise.
- D. Pump Connections: Flanged.

2.03 IN-LINE CIRCULATORS

- A. Type: Horizontal shaft, single stage, direct connected, with resiliently mounted motor for in-line mounting, oil lubricated, for 175 psig maximum working pressure.
- B. Casing: Cast iron.
- C. Impeller: Brass or bronze, keyed to shaft.
- D. Bearings: Two, oil lubricated bronze sleeves.
- E. Shaft: Alloy steel with stainless steel sleeve, integral thrust collar.
- F. Seal: Carbon rotating against a stationary ceramic seat, viton fitted, 225 degrees F maximum continuous operating temperature.
- G. Drive: Flexible coupling.

PART 3 EXECUTION

3.01 INSTALLATION

- A. Install pumps in accordance with manufacturer's instructions.
- B. Provide access space around pumps for service. Provide no less than minimum as recommended by manufacturer.
- C. Ensure pumps operate at specified system fluid temperatures without vapor binding and cavitation, are non-overloading in parallel or individual operation, and operate within 25 percent of midpoint of published maximum efficiency curve.
- D. Provide air cock and drain connection on pump casings.
- E. Provide drains for bases and seals, piped to and discharging into floor drains.
- F. Lubricate pumps before start-up.

END OF SECTION 23 21 23



Boiler Replacement

FOGARTY MEMORIAL SCHOOL

North Scituate, Rhode Island 02886

AA# 23018

SECTION 23 51 00

BREECHING, CHIMNEYS AND STACKS

PART 1 GENERAL

1.01 SECTION INCLUDES

- A. Manufactured double wall chimneys for No. 2 fuel oil-fired equipment.

1.02 RELATED SECTIONS

- A. Section 23 52 23 – Cast Iron Boilers

1.03 QUALIFICATIONS

- A. Manufacturer: Company specializing in the manufacture of products specified in this Section with minimum three years experience.

1.04 REGULATORY REQUIREMENTS

- A. Conform to applicable code for installation of No. 2 fuel oil burning appliances and equipment.

PART 2 PRODUCTS

2.01 DOUBLE WALL POSITIVE PRESSURE VENTS

- A. Manufacturers: Selkirk Metalbestos, Metal-Fab, Van Packer, Stacks Inc., or approved equal.
- B. Stack and accessory fittings to be double wall type with minimum 2-inch thick ceramic insulation between walls, U.L.-listed for continuous operation at 1400°F under positive pressure.
- C. Inner pipe to be type 304 stainless steel of 0.035" minimum thickness for sizes through 36" ID and minimum thickness of 0.048" for sizes over 36" ID.
- D. Construct outer jacket of aluminized steel where located inside building, and Type 304 stainless steel where located outside building. Minimum thickness of outer jacket to be 24 gage for sizes 10 inches to 24 inches and 20 gage for sizes 28 inches to 48 inches.
- E. Ceramic insulation (1", 2", 3" or 4")
 - a. 4" clearance for 1400°F (760°C) Chimney
 - b. 2" clearance for Building Heating Appliance Chimney
 - c. 2" clearance for Type "L" VentRated For:
 - a. Continuous operation at zero inch (0") clearance to non-combustibles.
 - b. Venting negative, neutral, and positive pressure applications.
 - c. Venting flue gasses from gas, liquid, and solid fuel fired appliances.
 - d. Positive pressures up to 60 inches water column.
- F. Join sections with high temperature acid-resistance joint cement and steel drawbands. Stacks to be self supporting and mounted on a concrete foundation. Allow for expansion of stacks from -20°F. to 1100°F.

- G. Provide all necessary accessories including flashing, counter-flashing, cable guys where required, cleanout, drain, exit cone, roof thimble and necessary supports. Coat all external welded joints and seams with galvanized paint. Provide expansion guides for stacks over 40 feet in height.

2.02 BREECHINGS

- A. Construct breechings over 10 inches in diameter of 12 gauge ASTM A527 galvanized steel with ANSI/ASTM A525 G90 zinc coating. All longitudinal seams to be welded. End to end joints may be made with welded connections or companion flanges. Coat all external welded joints and seams with galvanized paint.
- B. Provide adjustable self-actuating barometric draft dampers, where required or where indicated, full size of breeching.
- C. Provide cleanout doors where indicated on plans or at end point of breeching. Doors to be same gauge as breeching,
- D. Fabricate breeching fittings to match adjoining breechings. Fabricate elbows with center-line radius equal to 1.5 times breeching diameter. Limit angular tapers to 20 degrees maximum.

PART 3 EXECUTION

3.01 APPLIANCE VENTING:

- A. Install stack, breeching, and accessories in accordance with the manufacturer's recommendations, maintaining minimum clearances from combustibles specified in UL listing.
- B. Support breechings from building structure with suitable ties, braces, hangers and anchors to hold shape and prevent buckling. Minimum support for vertical sections shall be at all floor penetrations. Support from floor structure, roof structure, or adjacent structural surfaces. Verify load bearing capacity of support points with Architect/Engineer.
- C. Install breechings with a minimum of joints. Align connections accurately and maintain smooth internal surfaces.
- D. Maintain UL listed minimum clearances from combustibles.
- E. Install stacks plumb. Pitch breeching upward from fuel-fired equipment to chimney or stack.
- F. Provide drain points as shown and per the manufactures recommendation to allow proper draining of condensate. Provide Flue Gas Condensate pH Neutralization at each drain piping termination point.
- G. Clean breechings, chimneys, and stacks during installation, removing dust and debris.
- H. At appliances, provide slip joints to allow removal of appliances without removal or dismantling of breechings, chimneys, or stacks.
- I. Seal all joints of positive pressure stacks and breeching in accordance with manufacturer's recommendations, using only sealants recommended by stack manufacturer.

3.02 CLEANING AND PROTECTION

- A. Clean breeching internally during installation to remove dust and debris. Clean external surfaces to remove welding slag and mill film.
- B. At ends of breeching and chimneys which are not completed or connected to equipment, provide temporary closure which will prevent entrance of dust and debris until final connections are made.

END OF SECTION 23 51 00



Boiler Replacement

FOGARTY MEMORIAL SCHOOL

North Scituate, Rhode Island 02886

AA# 23018

SECTION 23 52 23

CAST IRON BOILERS

PART 1 GENERAL

1.01 SECTION INCLUDES

- A. Boilers.
- B. Controls and boiler trim.
- C. Hot water connections.
- D. No. 2 fuel oil connection.
- E. Circulator.

1.02 RELATED SECTIONS

- A. Section 23 21 14 - Hydronic Specialties.

1.03 REFERENCES

- A. ANSI/ASME SEC4 - Boiler and Pressure Vessel Codes - Rules for Construction of Heating Boilers.
- B. ANSI/ASME SEC8D - Boilers and Pressure Vessel Codes - Rules for Construction of Pressure Vessels.
- C. ANSI/NFPA 70 - National Electrical Code.
- D. HI (Hydronics Institute) - Testing and Rating Standard for Cast Iron and Steel Heating Boilers.

1.04 OPERATION AND MAINTENANCE DATA

- A. Submit operation and maintenance data under provisions of Division 1 Specifications.
- B. Include manufacturer's descriptive literature, operating instructions, cleaning procedures, replacement parts list, and maintenance and repair data.

1.05 QUALITY ASSURANCE

- A. Manufacturer: Company specializing in manufacturing the products specified in this Section with minimum three years documented experience.

1.06 REGULATORY REQUIREMENTS

- A. Conform to applicable code for internal wiring of factory wired equipment.

- B. Conform to ANSI/ASME SEC4 and SEC 8D for boiler construction. Boiler shall meet ANSI/ASME CSD-1 approval, have National Board certification and be UL approved.
- C. Units: ASME-rated construction, with ASME stamp on boiler.

1.07 WARRANTY

- A. Provide ten-year pro-rated warranty under provisions of Division 1 Specifications.
- B. Warranty: Include coverage for cast iron boiler sections.

1.08 GENERAL

- A. Furnish and install low pressure, wet base, cast iron sectional boiler(s) with power burner(s) that pressurize the firebox and operate under forced and balanced draft.
- B. Assemble and install boiler-burner unit(s) in compliance with manufacturer's installation instructions.
- C. Boilers shall be triple-pass hot water heating boiler as manufactured by Viessmann, or approved equal; furnish boiler(s) with burner(s) capable of burning No. 2 fuel oil.
 - 1. (B) Boiler-burner unit Field assembled (standard).
 - 2. (A) Boiler-burner unit with factory assembled sections.
 - 3. (P) Boiler-burner unit completely packaged and fire tested
 - 4. No. 2 fuel oil.
 - 5. Water boiler.
 - 6. Forced or balanced draft; furnish with barometric damper as required by boiler manufacturer.
- D. Boiler(s) shall have rated output(s) at 100% firing rate of capacities as noted on the Project Drawings..
- E. Boiler(s) shall be manufactured to conform to Section IV of the ASME Boiler and Pressure Vessel Code.
 - 1. Individual sections (and section assembly) to be hydrostatically pressure tested at factory in accordance with ASME requirements.
 - 2. Maximum 80 PSIG allowable working pressure as part of section with ASME symbol.
- F. Submittals
 - 1. Submit shop drawings and product data.
 - 2. Submittal packet to include boiler (and burner) manufacturer descriptive literature, installation instructions, operating instructions, and maintenance instructions.

PART 2 PRODUCTS

2.01 BOILER

- A. General: The hot water heating boiler shall incorporate a triple-pass cast iron heat transfer design. The boiler design shall allow for #2 fuel oil, natural gas and propane gas. Venting shall be standard Category I, non-condensing and negative draft. The control packages shall come pre-wired for the boiler/burner combination.

Combustion efficiency on natural gas and propane shall not be below 85%, as tested in accordance with the harmonized standard ANSI Z21.13.CSA 4.9. Combustion efficiency on #2 fuel oil shall not be below 88%.

ASME maximum allowable working pressure (MAWP): 75 psig;
ASME maximum water temperature (Fixed High Limit): 248°F (120°C).

The heat exchanger filled with water shall weigh no less than 4652 lbs (2110 kg) excluding the burner, controls and jacketing. Input rate per heat exchanger surface area shall not exceed 8.1 MBH/ft² (25.7 kW/m²) for oil, and 8.4 MBH/ft² (26.5 kW/m²) for gas, based on input at full fire.

No additional safety devices shall be required to safeguard against low flow conditions.

The boiler shall be able to supply a temperature of up to 210°F (99°C) at 75 psig.

Boiler minimum return water temperature shall not be below 104°F (40°C) on oil and 127°F (52.8°C) on gas.

Supply/return piping shall incorporate one of the following two methods for protecting the boiler against flue gas condensation: a 100% bypass valve or a 30% bypass pump.

A return water distribution tube shall be standard equipment, for reducing thermal stress associated with uneven water flow between sections.

The standard control options shall be able to operate independently, or integrate with building management system protocols as referenced in the control section.

Construction: The combustion chamber and flue gas passageways shall be constructed of sectional cast iron, and shall have a triple-pass design. The grade of cast iron shall be lamellar graphite.

The water side of the heat exchanger shall use a press-nipple design between sections to allow transportation of individual sections and reliable field assembly.

The heat exchanger shall have a full-swing door, left- or right-hinge, to allow for easy inspection and cleaning.

The R-value of the insulation shall be equivalent to 4" (100 mm) fiberglass with nylon backing.

Certifications: All individual components shall be accepted as part of the system under the governing body having jurisdiction. Field approval shall not be required for any component. Boiler shall be CSA approved and shall be built in compliance with ASME Section IV, carrying the "H" stamp.

The boiler shall have the following approvals and listings, or be in compliance with:
CSA, CRN, ASME, I=B=R, NY City approval, MA State approval

2.02 BOILER BURNER

- A. Burner: Weishaupt WM-L10/2; fully modulating.
- B. General: The burner shall be a forced draft automatic burner designed to burn #2 fuel oil.

Burner Housing: The burner housing shall be made of cast aluminum, and shall be capable of hinging open to the left or to the right.

The burner housing shall incorporate the following features:

- A flange safety interlock switch to prevent the burner from starting when in the open position
- A self-checking differential air pressure switch
- A large sight glass for viewing the flame
- A removable cover to allow free access to serviceable components

Fan: The blower wheel shall be statically and dynamically balanced.

Air Intake: The air intake shall consist of multiple aluminum air intake vanes on the suction side for combustion air regulation. Air louvers shall be controlled by a dedicated stepper motor having 900 settable increments from 90 angular degrees (open) to 0 angular degrees (closed). Air louvers shall be driven to the fully closed position during the "off" cycle to minimize draft losses. The air intake shall include sound attenuating material, and a screen to reduce the likelihood of foreign material entering the blower.

Combustion Head: The flame tube and diffuser assembly shall be made of stainless steel alloy, and shall have a temperature rating of 1470°F. The diffuser, nozzle assembly and all serviceable components shall be accessible without need for burner removal. The combustion head shall be adjustable such that the pressure drop across the diffuser can be optimized to match the maximum firing rate of the burner.

Burner Management System: The burner management system shall integrate fuel/air ratio control, flame safeguard functions, load control and communications into one control system. The burner management system shall have four levels of password protection.

The fuel/air ratio control system shall be free of linkages which connect fuel control and air control functions into a common servomotor or actuator. Fuel and air control components shall be individually controlled by dedicated stepper motors programmable via the keypad. The fuel/air ratio shall be infinitely adjustable throughout the firing range.

The burner shall have independent ignition position (independent of any other firing position).

All functions including burner history, commissioned values, operating parameters and pressure/temperature settings shall be accessible/adjustable without the need for a laptop computer or other special tools.

Both the programming pad and the main control module shall hold programmed data with capability of uploading/downloading from one to the other.

The flame safeguard system shall be integrated into the control system and shall include sensor electrode (standard) or QRI infrared flicker detector (option). The combustion control system shall include built-in PID pressure/temperature control and time/temperature adjustable cold start function to protect the boiler from thermal shock.

The control system shall have selectable operating modes to allow for the following:

- Direct modulation via the building automation system using either a 4-20 mA, 2-10V or floating type operating signal.
- Set-point adjustment via the building automation system using either a 4-20 mA, 2-10V or floating type operating signal.

The burner control system shall be capable of providing the following functions and data signals via a MODBus interface:

- Burner ON/OFF
- Load signal
- Set-point and process value
- Operating information
- Actual load position of burner
- Lock-out with failure code
- Actual position (on/off) of air pressure switch, valves, fan, gas pressure, flame supervision
- Start-up counter
- Actual operating hours

The control system shall incorporate a 4-line, 64 character LCD display (ABE). The ABE display shall be capable of being mounted either on the burner or in a remote control panel. ABE shall be easy to remove from its mounting while remaining connected to the wiring harness enabling a technician to have "hand held" adjustment capability.

Motor: The burner shall have a three-phase (or single-phase) TEFC blower motor fully compatible for use with variable frequency drive.

Certifications: All individual components shall be accepted as part of the system under the governing body having jurisdiction. Field approval shall not be required for any component.

The minimum standards for #2 fuel oil burners are:

- CAN/CSA B139 Installation Code For Oil Burning Equipment (for Canada)
- CSA C22.1 Canadian Electrical Code and/or local electrical codes (for Canada)
- NFPA 31 Standard for the Installation of Oil Burning Equipment (for U.S.)
- ANSI/NFPA 70 National Electrical Code (for U.S.)

2.03 BOILER CONTROLS

A. Vitotronic 300-K, MW1B

General: The control unit shall provide control for up to 4 boilers in a system with one high temperature circuit and two mixing valve circuits with weather responsive reset. Additional circuits shall be added with the order of a mixing valve controller or a custom control panel. They shall use the LON communication protocol. A maximum of 5 systems shall be connected to the LON bus for monitoring by a building automation system. The outdoor reset supply temperature of every heating circuit shall result from the outside temperature, the set room temperature, the operating mode and the heating curve.

General Requirements: The controller shall have the following features:

- Menu driven graphical user interface.
- EPROM memory is maintained without main power.
- Control algorithms are PID-based.
- LON ready with integrated Viessmann LON communication Module.
- Quick connect plug & play system for low voltage controls.
- Communication with other protocols such as Modbus, BacNet and Ethernet/IP shall be available through an external gateway.

The controller shall be factory tested and approved by CSA as part of a package with the compatible boilers.

The controller shall be able to support the following output devices:

- (1) Domestic hot water pump.
- (1) High temperature Heating loop circulation pump without mixing valve.
- (2) Low Temperature heating loop circulation pumps in conjunction with mixing valves.
- (2) Heating loop modulating mixing valves.
- (1) DHW re-circulation pump.
- (1) System circulation pump.

Construction

Control Interface: The control shall be a multiple line graphic user interface (°F or °C) and shall have the following features:

- Able to display all system temperatures and set points.
- Displays unique fault message during an alarm.
- A program selection function.
- Domestic hot water temperature set point adjustment function.
- Information indicator with confirmation function.
- Operating status check button.

- Emission test switch.
- Adjust the display contrast.
- Temporary occupied mode function.
- Slope and shift adjustment for heating curve.

Additional Features: The controller shall have the following additional features:

- On/Off switch.
- Default factory settings reset function.
- Operating status indication light.
- Manual override switch.
- Fault Indicator light.
- Operating condition scans.
- Maintenance requirement status.
- Relay test function.
- Participant check (LON nodes).
- Quick heat up and quick set-back functions.
- Start-up and shut-down optimization functions.
- Warm weather shut-down.
- Energy savings mode.
- Ability to restore the control to factory defaults.

Boiler System Supply Water Temperature Control: Each controlled zone shall have a calculated heating curve which describes the required supply water temperature at different outside air temperatures. The slope and shift of each heating curve shall be adjusted to fit any type of building or system. The highest required temperature of all zones shall be used together with bias from an optional room temperature sensor to determine the common boiler supply temperature set-point. The boilers shall be sequenced to maintain this temperature, configured as having either two-stage or modulating burners.

Separate control strategies for condensing and non-condensing boilers shall be available.

Subject to the system design, there shall be a choice of three different start-up and shut-down programs, one gross calorific strategy and two net calorific strategies.

In the unoccupied mode, the supply water temperature set-point shall be reduced by a pre-determined amount. A call for domestic hot water or an external demand signal shall override this set-point to pre-determined values.

Control logic shall be equipped to protect the heating system from freeze-up if left powered during the off season.

Boiler Rotation: The boilers shall be rotated once a month according to an equal run-time strategy or on a schedule every 200 to 2000 hours. A dry contact shall be incorporated to make the current lead boiler the lag boiler whenever contact is closed. If the system has both condensing and non-condensing boilers, the condensing boiler shall be programmed to always be the lead.

Fault Management: If a fault occurs on a boiler, the fault code shall be indicated in the display window and by the flashing red fault lamp. A compiled failure alarm contact shall close in order to signal the alarm condition to a Building Automation System (BAS). The message shall also be broadcasted on the LON communication bus. The error history shall be saved to memory. An optional Output Module connected to the LON bus shall close a set of potential-free contacts for each of the following conditions: burner status, burner failure, high boiler temperature and low water cut-off alarm.

Scheduling: There shall be separate time schedules for central heating, DHW heating and the DHW re-circulation pump. Each device shall be able to be scheduled to switch between occupied and unoccupied modes up to four times per day.

Auxiliary Inputs: The following dry contact inputs shall be available to be wired to each boiler to control the following functions:

- System disable.
- External heat demand.
- Change lead boiler into the lag boiler.

Building Management System Interface: The controller shall use the LON communication protocol and shall be able to be fully integrated into a building automation system running on the LON protocol without having to use a gateway.

The controller shall have the ability, through the use of an Input Module, to accept a 0-10V signal from a Building Management System for the purpose of allowing remote control of the boiler supply water temperature set point.

The controller shall be able to fully integrate with Building Management Systems running on the BacNet or N2 communication protocols via a gateway.

Remote Communication Interface: The controller shall have the ability to be connected to a phone dialer, enabling remote control of any of the functions listed in the Auxiliary inputs section.

The controller shall have the ability to be connected to an Internet server interface, which shall allow access to all programming and operating parameters over the World Wide Web.

Certifications: All individual components shall be accepted as part of the system under the governing body having jurisdiction. Field approval shall not be required for any component.

All electrical wiring is to be done in accordance with the latest editions of:
CSA C22.1 Canadian Electrical Code and/or local electrical codes (for Canada)
ANSI/NFPA 70 National Electrical Code (for U.S.)

B. Vitotronic 100, GC1B

General: The control unit shall provide control for a single boiler with one high temperature heating circuit. Temperature control of the heating circuit shall be from internal set point control, optional 0-10VDC interface input into boiler control, dry contact 143/146 demand inputs or optional LON communication card. The control shall operate either a single-stage, two-stage or modulating burner as a function of set point boiler water temperature.

General Requirements: The controller shall have the following features:
Compatible with single-stage, two-stage and modulating burners.
EPROM memory is maintained without main power.
Control algorithms are PID-based.
LON ready with the addition of optional Viessmann LON communication module.
Quick connect plug & play system for low voltage controls.
Communication with other protocols such as Modbus, BacNet and Ethernet/IP shall be available.

The controller shall be factory tested and approved by CSA as part of a package with the compatible boilers.

The controller shall be able to support the following output devices:

- (1) Domestic hot water pump.
- (1) Boiler Pump.
- (1) Shunt pump for boiler return water temperature elevation.
- (1) Operation with Single Stage, Two Stage or modulating Burner.
- (1) Motorized modulating valve output for boiler isolation or return temperature elevation.

Construction

Control Interface: The control interface shall be menu driven with an alpha-numeric display (°F or °C) and shall have the following features:

- Able to display all system temperatures and set points.
- Displays unique fault message during and alarm.
- A program selection function.
- Domestic hot water temperature set point adjustment function.
- Information indicator with confirmation function.
- Boiler operating hours display.
- Number of burner starts display.
- Operating status check function.
- Emission test switch.
- Boiler supply water temperature set point adjustment function.

Additional Features: The controller shall have the following additional features:

- On/Off switch.
- Default factory settings reset function.
- Operating status indication light.
- Tamper-proof adjustable high limit.
- Manual override switch.
- TUV service switch (overrides AHL).
- Manual reset fixed high limit.
- Fault Indicator light.
- Integration of individual combustion air dampers or blowers using the Combustion Air Device Adapter.
- Operating condition scans.
- Maintenance requirement status.
- Relay test function.
- Option to incorporate a flue gas temperature sensor.
- Ability to restore the control to factory defaults.

The fixed high limit shall have the following tamper-proof feature: A locking mechanism which allows for lower temperature adjustments only. Once a lower temperature setting is adjusted, the limit cannot revert back to a higher temperature setting.

Fault Management: If a fault occurs on a boiler, the fault code shall be indicated in the display window and by the flashing red fault lamp. A compiled failure alarm contact shall close in order to signal the alarm condition to a Building Automation System (BAS). If a LON card is installed, the message shall also be broadcasted on the LON communication bus. The error history shall be saved to memory. An optional Output Module connected to the LON bus shall close a set of potential-free contacts for each of the following conditions: burner status, burner failure, high boiler temperature and low water cut-off alarm.

Auxiliary Inputs: The following dry contact inputs shall be available to be wired to each boiler to control the following functions:

- Boiler disable.
- Change between modulating to staged burner control.
- External heat demand.

Building Management System Interface: The controller shall use the LON communication protocol and shall be able to be fully integrated into a building automation system running on the LON protocol without having to use a gateway.

The controller shall have the ability, through the use of an Input Module, to accept a 0-10V signal from a Building Management System for the purpose of allowing remote control of the boiler supply water temperature set point.

The controller shall be able to fully integrate with Building Management Systems running on the BacNet or N2 communication protocols via a gateway.

Remote Communication Interface: The controller shall have the ability to be connected to a phone dialer, enabling remote control of any of the functions listed in the Auxiliary inputs section.

The controller shall have the ability to be connected to an Internet server interface, which shall allow access to all programming and operating parameters over the World Wide Web.

Certifications: All individual components shall be accepted as part of the system under the governing body having jurisdiction. Field approval shall not be required for any component.

All electrical wiring is to be done in accordance with the latest editions of:
CSA C22.1 Canadian Electrical Code and/or local electrical codes (for Canada)
ANSI/NFPA 70 National Electrical Code (for U.S.)

C. Vitogate 300 BN/MB

General: The Vitogate 300 BN/MB is a communication gateway that allows for data transfer between the Viessmann LON System, used with Viessmann equipment, and a Building Management System or Building Automation System using either BACnet or Modbus communication protocols. The Vitogate 300 shall offer a combination of both readable and readable/writable points available from the Viessmann equipment within the system.

The Vitogate 300 shall be capable of communicating with up to 1 Viessmann cascade control, and up to 8 boilers within a single system. The Vitogate 300 shall be capable of communicating with up to 4 Viessmann systems. The Vitogate 300 shall be offered in 2 versions, one version complete with an enclosure for remote mounting applications, the other as a DIN rail mountable version for installation into select equipment junction boxes.

General Requirements: The gateway shall have the following features:

- Communication with up to 1 cascade control and 8 boilers in a single system.
- Enclosure for remote mounting or wall mounting.
- Shipped complete with 24VDC Power Supply Unit.
- USB configuration back-up port.
- LAN connection port for communication with PC/Laptop, BACnet IP, or Modbus TC/IP
- RS485 port for communication using BACnet MS/TP or Modbus 485.
- Two LON communication ports for integration into the Viessmann LON system.

The gateway shall be factory tested and approved by CSA as part of a package with the compatible series of boilers.

Construction: Control Interface: The control interface shall be web browser driven, capable of displaying both metric and imperial units, and shall have a language selection menu. Menu driven selection functions, providing access to (but are not limited to) the following operating points:

- Able to display all system temperatures and set points.
- Displays unique fault message during an alarm.
- A program selection mode.
- Domestic hot water temperature set point adjustment.
- Operating status check.
- Slope and shift adjustment for heating curve.

Fault Management: If a fault occurs within the Viessmann system, the fault code shall be transmitted to the Building Management System or Building Automation System. Any fault will be displayed as a unique fault code relative to the fault generated.

Certifications: All individual components shall be accepted as part of the system under the governing body having jurisdiction. Field approval shall not be required for any component.

The gateway shall be CSA Certified for U.S. and Canada.

All electrical wiring is to be done in accordance with the latest editions of:
CSA C22.1 Canadian Electrical Code and/or local electrical codes (for Canada)
ANSI/NFPA 70 National Electrical Code (for U.S.)

2.04 CIRCULATOR

- A. Type: Horizontal shaft, single stage, direct connected, with resiliently mounted motor for inline mounting, oil lubricated, for 125 psig maximum working pressure.
- B. Casing: Cast iron.
- C. Impeller: Cadmium plated steel, keyed to shaft.
- D. Bearings: Two, oil lubricated bronze sleeves.
- E. Shaft: Alloy steel with copper sleeve, integral thrust collar.
- F. Seal: Carbon rotating against a stationary ceramic seat, 225 degrees F maximum continuous operating temperature.
- G. Drive: Flexible coupling.

PART 3 EXECUTION

3.01 INSTALLATION

- A. Install in accordance with manufacturer's instructions.
- B. Provide for connection to electrical service.
- C. Provide connection of fuel oil service in accordance with applicable codes.
- D. Pipe relief valves to nearest floor drain.
- E. Provide a fire-matic switch over the burner(s), arranged to shut down the burner(s) upon activation.
- F. Install circulator and diaphragm expansion tank on boiler.

3.02 MANUFACTURER'S FIELD SERVICES

- A. Prepare and start systems under provisions of applicable Specification Sections.
- B. Submit written report after start-up including control settings and performance chart of control system.

3.03 BOILER CONTROL SYSTEM – SEQUENCE OF OPERATION

- A. Hot water system to be in operation whenever the outside air temperature is below 60 degrees F. (adj.). System enable/disable to be performed automatically, by an outside air temperature controller. When enabled, the pump selected as the “primary” pump is to run continuously. Selection of the primary pump is an automatic procedure, performed by the existing Building Energy Management System. Upon failure of the primary pump, the backup pump is to automatically start. Provide water flow switch in boiler return piping loop; water flow must be proven before boiler(s) are

allowed to fire.

- B. Boiler “inner loop” circulating pumps operate to maintain constant flow and consistent temperature through the boilers. Pumps are controlled by simple ON-OFF switches, and both should be in operation whenever the boiler system is enabled.
- C. Boiler sequencing panel controls the operation of both boilers, in order to achieve and maintain hot water temperature setpoint. Setpoint is to be a function of outside air temperature. As the outside air temperature increases, the hot water temperature setpoint is “reset” downwards. Hot water temperature sensor is located in the hot water supply piping common to both boilers.
- D. Boiler sequencing panel has the capability of boiler lead/lag alternation. Upon initial call for boiler operation, i.e., if the hot water temperature falls below setpoint, sequencing panel signals the combustion air damper to open. When the damper is substantially open, the lead boiler is allowed to operate. Sequencing panel controls the proportional firing rate of the lead boiler in order to maintain setpoint. If the temperature continues to drop, then the lag boiler is allowed to operate as well, with the sequencing panel controlling this boiler in the same manner as the lead boiler.
- E. As the hot water temperature rises toward setpoint, the boilers are disengaged in the reverse order that they were engaged. When the call for boiler operation ceases altogether, the combustion air damper motor is de-energized, and the damper springs shut.
- F. With the boiler system enabled (i.e. whenever the outside air temperature is below 60 degrees F (adj.)) operation of the lead boiler is preceded by the operation of the combustion air damper(s). Upon a call for boiler operation, combustion air damper actuator(s) are energized, and the combustion air damper(s) begin to stroke open. Only after the damper(s) have stroked substantially open is the lead boiler allowed to fire.

END OF SECTION 23 52 23

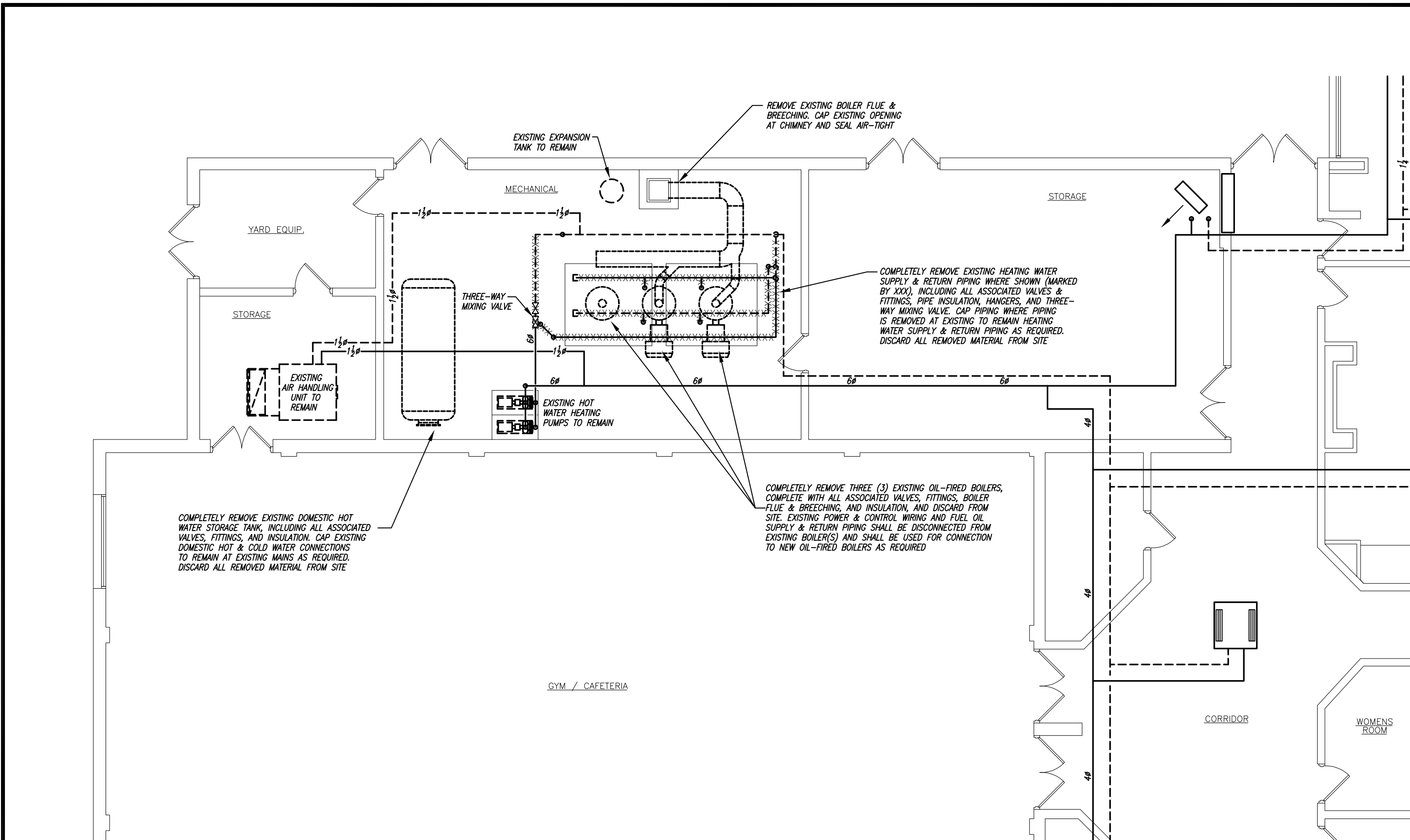

1 FLOOR PLAN - MECHANICAL DEMOLITION
SCALE: 1/8" = 1'-0"

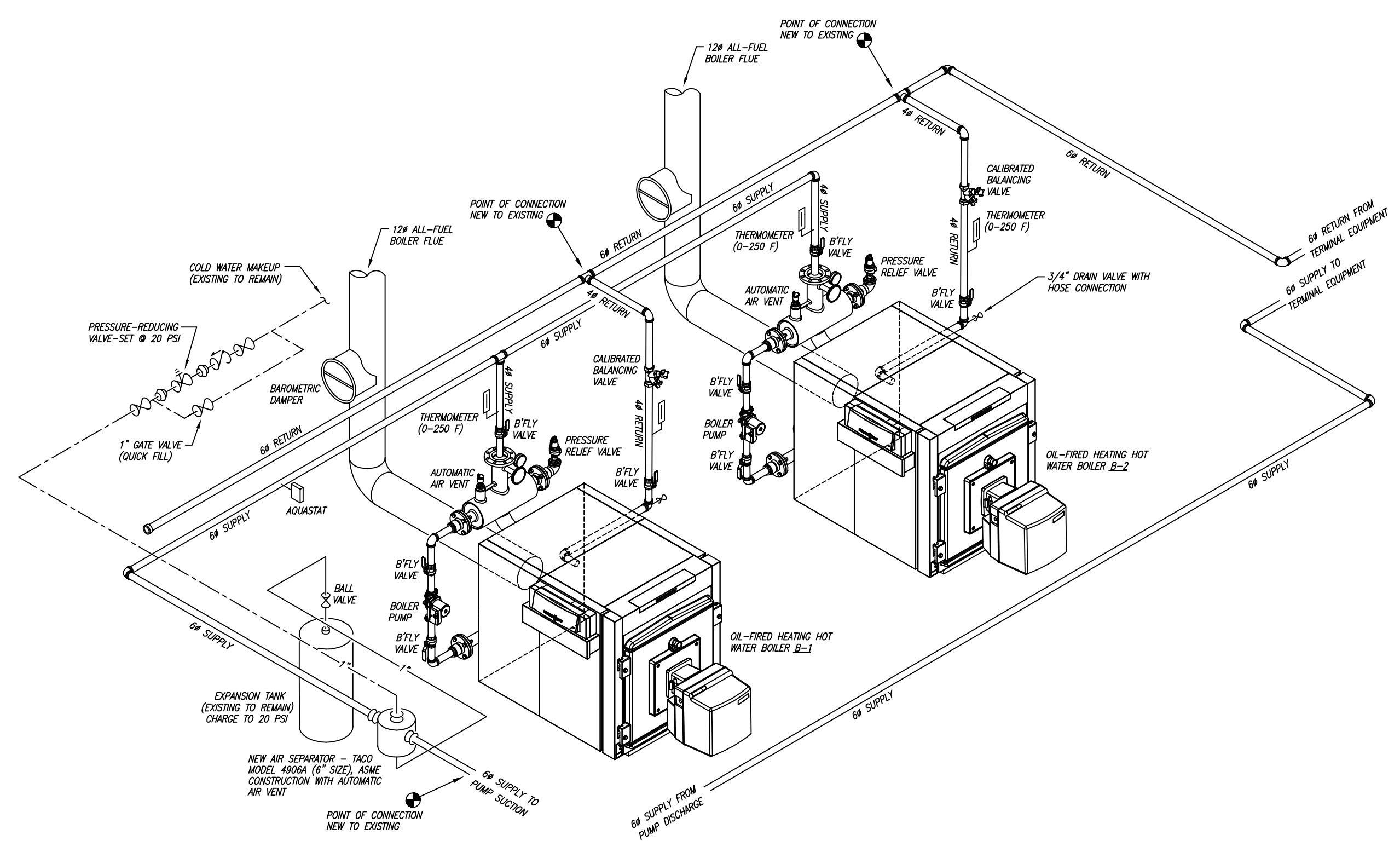

MULTIPLE HEATING HOT WATER BOILER PIPING DETAIL
NO SCALE

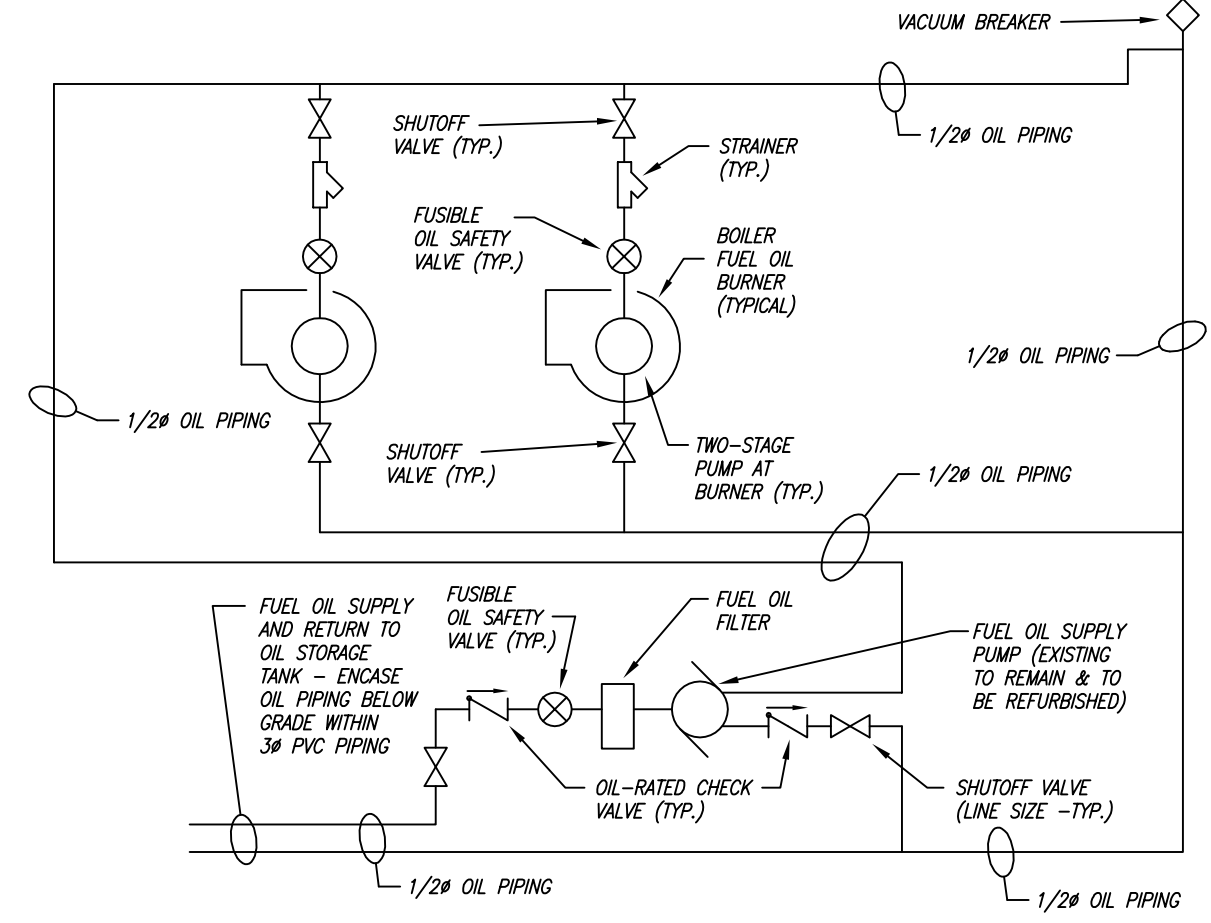

FUEL OIL PIPING DETAIL
NO SCALE

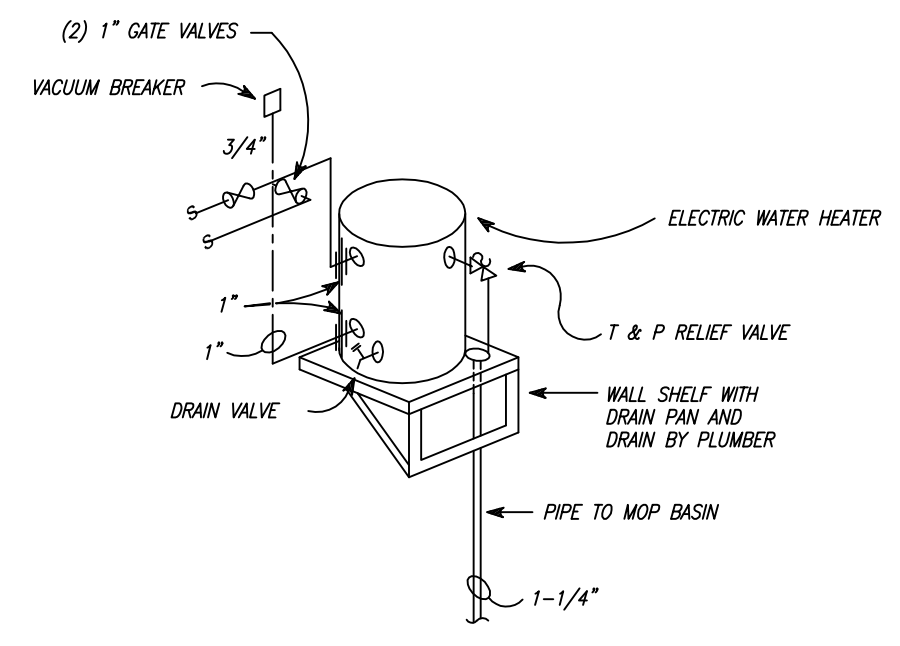

DOMESTIC WATER HEATER DETAIL
NO SCALE

NOTE - FURNISH AND INSTALL THE FOLLOWING ELECTRIC WATER HEATERS:
(1) RUAO MODEL EESP-6, 6 GALLONS STORAGE, 3,000 WATT ELEMENT, 12 GPH RECOVERY AT 100°F RISE, 208 V/1Φ. INSTALL IN KITCHEN SPACE NEAR DASHWASH MACHINE, AND CONNECT NEW 1" DOMESTIC COLD WATER & 1" DOMESTIC HOT WATER PIPING TO EXISTING PIPING ABOVE BATHROOM GROUP CEILING. PROVIDE EACH WITH THERMOSTATIC MIXING VALVE TO LIMIT DISCHARGE WATER TEMPERATURE TO 105°F
(2) RUAO MODEL EESP-20, 20 GALLONS STORAGE, 4,500 WATT ELEMENT, 18 GPH RECOVERY AT 100°F RISE, 208 V/1Φ. INSTALL IN KITCHEN SPACE NEAR DASHWASH MACHINE, AND CONNECT NEW 1" DOMESTIC COLD WATER & 1" DOMESTIC HOT WATER PIPING TO EXISTING PIPING ABOVE KITCHEN CEILING

WATER BOILER SCHEDULE						
SYMBOL	OUTPUT (AHRJ BTU-2000)	OIL INPUT	MAX. WORKING PRESSURE	RELIEF VALVE SETTING	FLUE COLLAR DIAMETER	ELECTRICAL DATA
B-1	1,319,000 BTUH	10.8 GPH	75 PSI	75 PSI	12"	MOTOR HP / VOLTAGE 1/3 HP / 120 V/1Φ
B-2	1,319,000 BTUH	10.8 GPH	75 PSI	75 PSI	12"	MOTOR HP / VOLTAGE 1/3 HP / 120 V/1Φ

1. FURNISH EACH BOILER COMPLETE WITH WEISHAUPPT WM-L10/2 FULLY-MODULATING LINKAGELESS OIL BURNER WITH DOOR SWITCH, 30K LPT PACKAGE INCLUDING CIRCULATOR PUMP, CAST IRON FLANGE SET, (2) FULL-PORT BALL VALVES, FLOW CHECK VALVE, STRAP-ON SENSOR, AND MOTOR STARTER, COMBUSTION AIR INTERFACE DEVICE FOR VITOTRONIC CONTROLS, AND COMPLETE DIGITAL MASTER BOILER CONTROL WITH OUTDOOR-INDOOR RESET

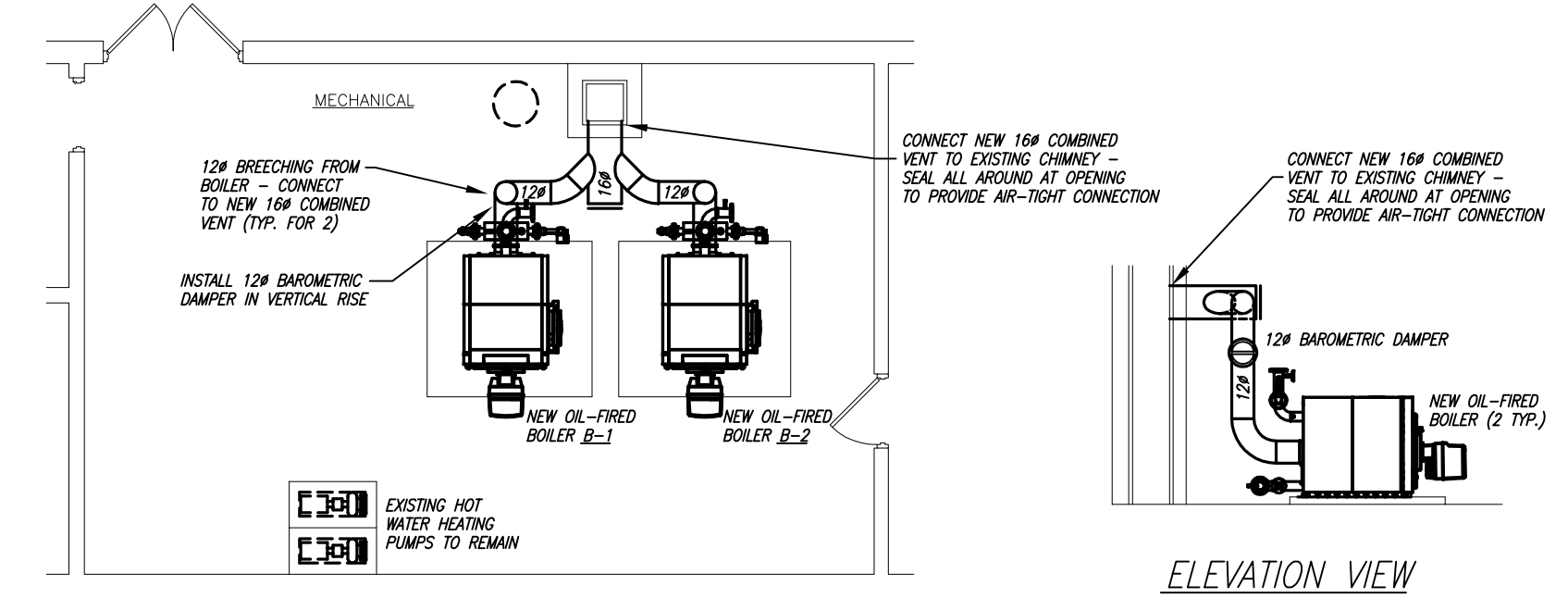

PARTIAL PLAN - BOILER VENT/CHIMNEY CONNECTIONS
SCALE 1/8" = 1'-0"

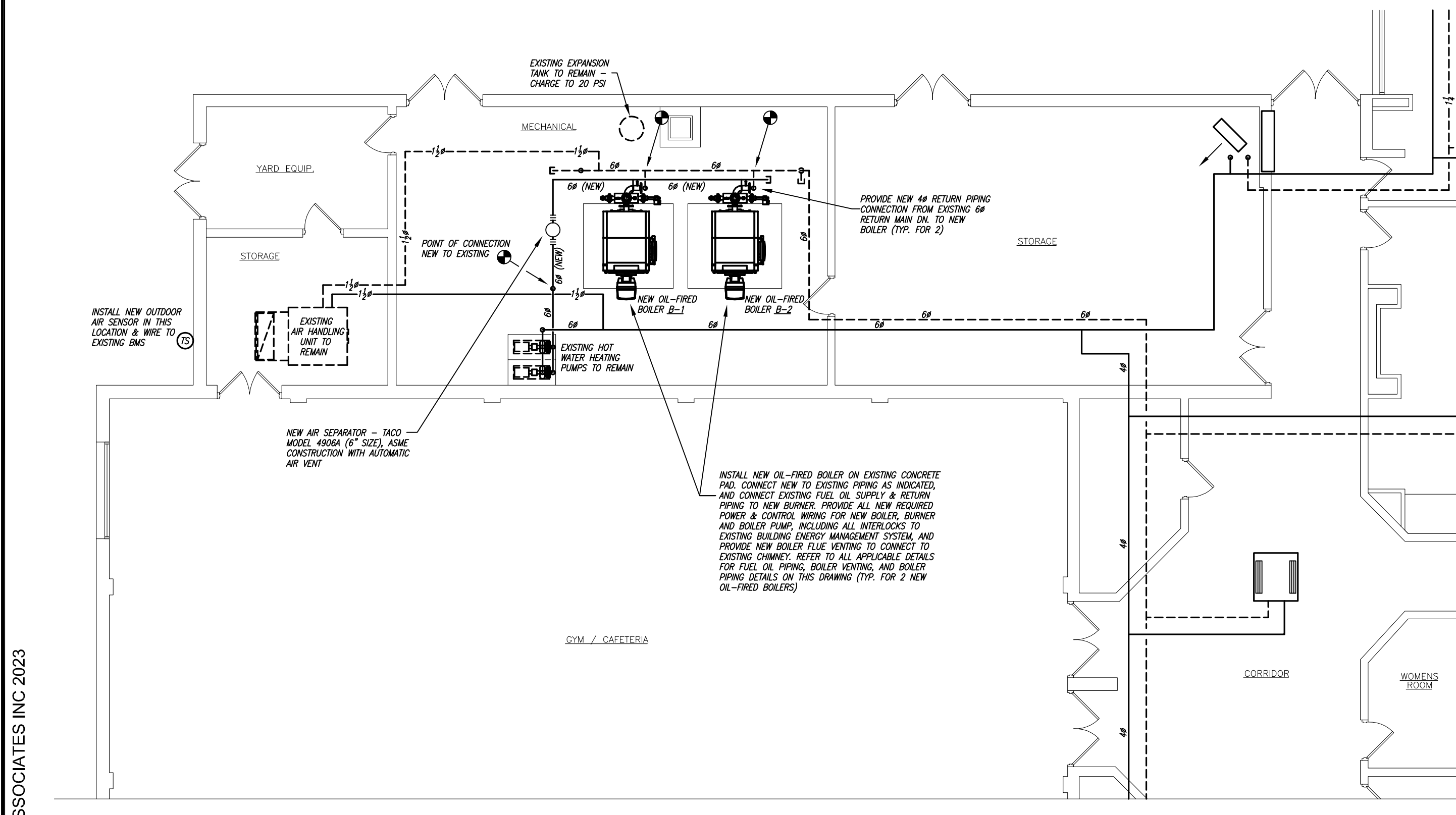

2 FLOOR PLAN - MECHANICAL PROPOSED WORK
SCALE: 1/8" = 1'-0"

AHARONIAN & ASSOCIATES INC. ARCHITECTS
310 George Washington Highway Suite 100
Smithfield, Rhode Island
02917
T 401-232-5010
F 401-232-5080
WWW.ARCH-ENG.COM

DISCLAIMER
OWNERSHIP AND USE OF DOCUMENTS, DRAWINGS AND SPECIFICATIONS ARE INSTRUMENTS OF PROFESSIONAL SERVICE AND SHALL REMAIN THE PROPERTY OF THE ARCHITECT. THESE DOCUMENTS ARE NOT TO BE USED, IN WHOLE OR IN PART, FOR ANY OTHER PROJECTS OR PURPOSES OR BY ANY OTHER PARTIES THAN THOSE PROPERLY AUTHORIZED BY CONTRACT WITHOUT THE EXPRESS WRITTEN AUTHORIZATION OF THE ARCHITECT.

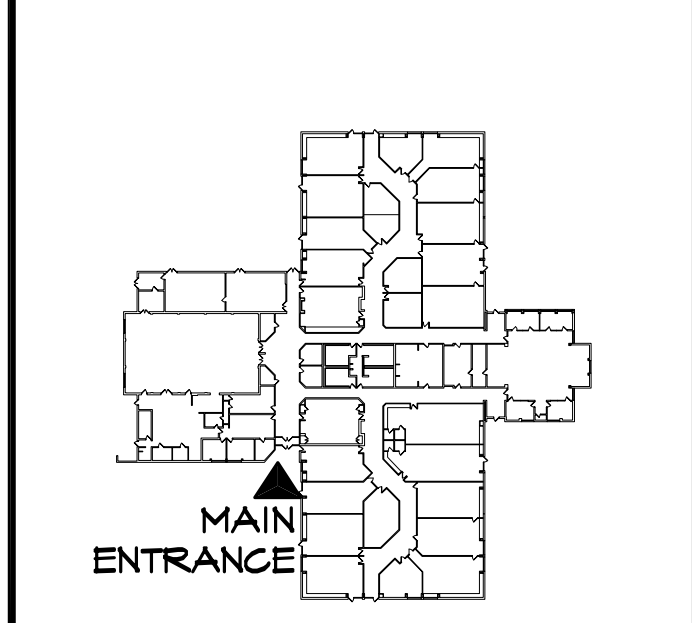

KEY PLAN

REVISIONS		
NUMBER	REMARKS	DATE

ROBERT KYLE BAKER
No. 5333
REGISTERED PROFESSIONAL ENGINEER
3/31/23
R.K. BAKER & ASSOCIATES
ENGINEERS AND CONSULTANTS
21 BURDICK DRIVE
CRANSTON, RI 02910
(401) 974-5108

FOR CONSTRUCTION

PROJECT TITLE

Fogarty MEMORIAL SCHOOL
736 Snake Hill Road
North Scituate, RI 02857
BOILER & WATER HEATER RENOVATIONS

DRAWING TITLE
PLANS, SCHEDULES DETAILS & NOTES MECHANICAL

DATE MARCH 31, 2023	PROJ NO 23018
DRAWN BY RKB	CHECKED BY RKB

DRAWING NUMBER
M1.1